

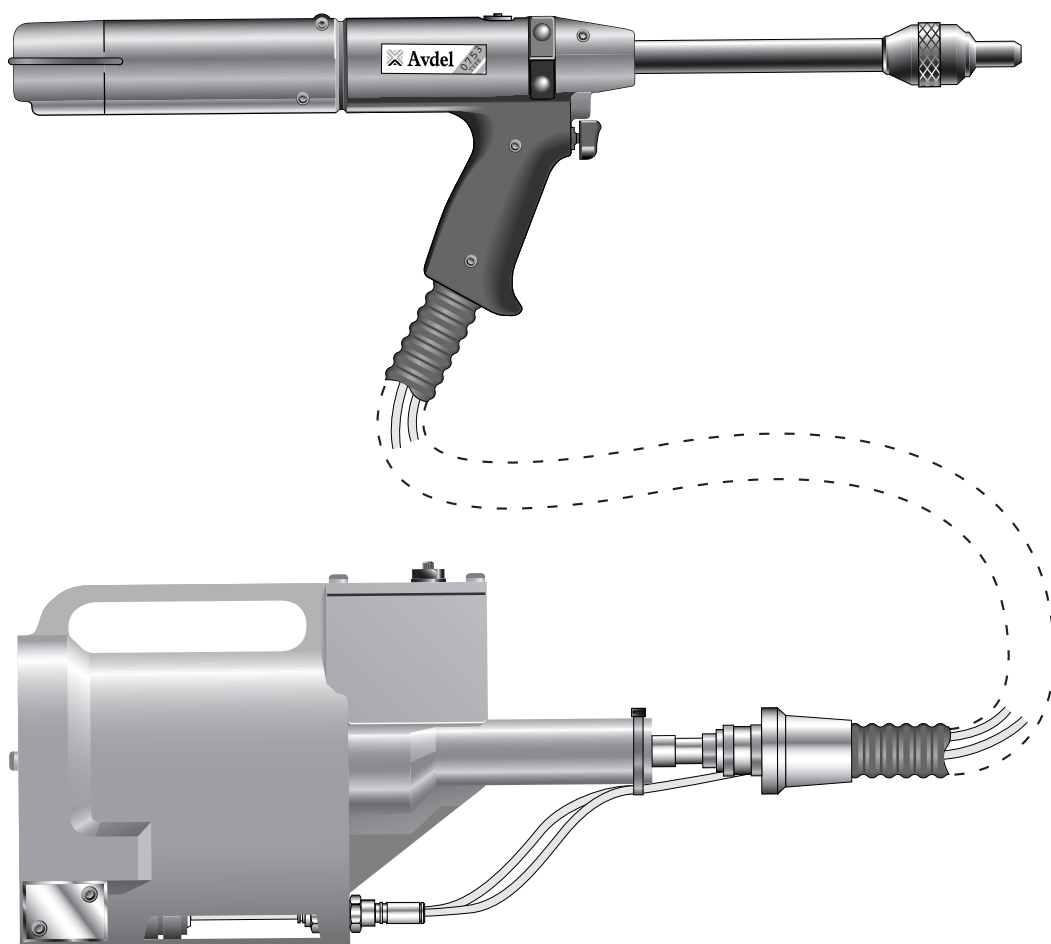

An Acument™ Global Technologies Company

Instruction Manual



0753 MkII type
07530-07532

Hydro-Pneumatic Power Tool

Contents

Safety Rules	4	Maintenance	
Specifications		Dismantling 07530-02200 Mkl	24-25
Specification for 0753 Mkl Type Tool	5	Dismantling 07532-02200 Mkl	26-27
Specification for 07531 Intensifier	5	General Assembly and Parts List 07530-02200 Mkl	28-29
Intent of Use	6	General Assembly and Parts List 07532-02200 Mkl	30-31
Tool Dimensions	7	Intensifier 07531-02200	32-33
Putting into Service		Pilot valve 07005-00590 Spares Information	34-35
Air Supply	8	Priming	
Mechanical Cursors	9	Oil Details	36
Cursor	10	Hyspin VG 32 and AWS 32 Oil Safety Data	36
Loading and Re-loading the Tool	10-11	Priming Procedure	36
Operating Procedure	11	Fault Diagnosis	
Mandrel Follower Springs Identification and Orientation	12	Symptom, Possible Cause & Remedy	37
Nose Assemblies			
Nose Jaws	13		
Selecting a Nose Jaw	14		
Nose Jaw Selection Tables	15-16		
Mandrels and Mandrel Follower Springs	17		
Chobert® and Grovit® Selection Tables	17-18		
Briv® Selection Tables	19-20		
Mandrel Head Types and 'P' Length	20		
Avlug®, Avsert®, Avtronic® and Rivscrew® Selection Tables	21		
Servicing the Tool			
Daily / Weekly	22		
Moly Lithium Grease EP 3735 Safety Data	22		
Service Kit	23		

LIMITED WARRANTY

Avdel makes the limited warranty that its products will be free of defects in workmanship and materials which occur under normal operating conditions. This Limited Warranty is contingent upon: (1) the product being installed, maintained and operated in accordance with product literature and instructions, and (2) confirmation by Avdel of such defect, upon inspection and testing. Avdel makes the foregoing limited warranty for a period of twelve (12) months following Avdel's delivery of the product to the direct purchaser from Avdel. In the event of any breach of the foregoing warranty, the sole remedy shall be to return the defective Goods for replacement or refund for the purchase price at Avdel's option. THE FOREGOING EXPRESS LIMITED WARRANTY AND REMEDY ARE EXCLUSIVE AND ARE IN LIEU OF ALL OTHER WARRANTIES AND REMEDIES. ANY IMPLIED WARRANTY AS TO QUALITY, FITNESS FOR PURPOSE, OR MERCHANTABILITY ARE HEREBY SPECIFICALLY DISCLAIMED AND EXCLUDED BY AVDEL.

Avdel UK Limited policy is one of continuous product development and improvement and we reserve the right to change the specification of any product without prior notice.

Safety Rules

This instruction manual must be read with particular attention to the following safety rules, by any person installing, operating, or servicing this tool.

- 1 Do not use outside the design intent.
- 2 The Hand Tool and Intensifier have been tested as separate items and combined. They must only be used together and under no circumstances for any other purposes.
- 3 Do not use equipment with this tool/machine other than that recommended and supplied by Avdel UK Limited.
- 4 Any modification undertaken by the customer to the tool/machine, nose assemblies, accessories or any equipment supplied by Avdel UK Limited or their representatives, shall be the customer's entire responsibility. Avdel UK Limited will be pleased to advise upon any proposed modification.
- 5 The tool/machine must be maintained in a safe working condition at all times and examined at regular intervals for damage and function by trained competent personnel. Any dismantling procedure shall be undertaken only by personnel trained in Avdel UK Limited procedures. Do not dismantle this tool/machine without prior reference to the maintenance instructions. Please contact Avdel UK Limited with your training requirements.
- 6 The tool/machine shall at all times be operated in accordance with relevant Health and Safety legislation. In the U.K. the "Health and Safety at Work etc. Act 1974" applies. Any question regarding the correct operation of the tool/machine and operator safety should be directed to Avdel UK Limited.
- 7 The precautions to be observed when using this tool/machine must be explained by the customer to all operators.
- 8 Always disconnect the airline from the tool/machine inlet before attempting to adjust, fit or remove a nose assembly.
- 9 Do not operate a tool/machine that is directed towards any person(s) or the operator.
- 10 Always adopt a firm footing or a stable position before operating the tool/machine.
- 11 Ensure that vent holes do not become blocked or covered and that hoses are always in good condition.
- 12 The operating pressure shall not exceed 7 bar (100 lbf/in²).
- 13 The combination of fastener, mandrel, hole size and sheet thickness shall be in accordance with Avdel UK Limited Specifications.
- 14 Do not operate the tool if it is not fitted with a complete nose assembly unless specifically instructed otherwise.
- 15 When using the tool, the wearing of safety glasses is required both by the operator and others in the vicinity to protect against fastener ejection, should a fastener be placed 'in air'. We recommend wearing gloves if there are sharp edges or corners on the application.
- 16 Take care to avoid entanglement of loose clothes, ties, long hair, cleaning rags etc. in the moving parts of the tool which should be kept dry and clean for best possible grip.
- 17 When carrying the tool from place to place keep hands away from the trigger/lever to avoid inadvertent startup.
- 18 Excessive contact with hydraulic oil should be avoided. To minimize the possibility of rashes, care should be taken to wash thoroughly.

I M P O R T A N T

While a small amount of wear and marking will naturally occur through normal and correct use of mandrels, they must be regularly examined for excessive wear and marking, with particular attention to the head diameter, the tail jaw gripping area of the shank or heavy pitting of the shank and any mandrel distortion. Mandrels which fail during use could forcibly exit the tool. It is the customer's responsibility to ensure that mandrels are replaced before any excessive levels of wear and always before the maximum recommended number of placings. Contact your Avdel representative who will let you know what that figure is by measuring the broach load of your application with a calibrated test tool. These tools can also be purchased under Part Number 07900-09080, supplied with all necessary information for testing in this manual.

Specifications

Specification for 0753 Mk II Type Tool

Air Pressure	Minimum - Maximum	5-7 bar (70-100 lbf/in ²)
Free Air Volume Required	@ 5.1 bar /75 lbf/in ²	2.6 litres (0.09 ft ³)
Stroke	Minimum	30.0 mm (1.18 in)
Pull Force	@ 5.5 bar /80 lbf/in ²	3.89 kN (875 lbf)
Cycle time	Approximately	1 second
Noise Level	Less than	70 dB(A)
Weight	Pistol	1.2 kg (2.64 lb)
Vibration	Less than	2.5 m/s ² (8 ft/s ²)

Specification for 07531 Intensifier

Air Pressure	Minimum - Maximum	5-7 bar (70-100 lbf/in ²)
Intensification Ratio		32:1

Intent of Use

The pneumatic 0753 MkII type tool is designed to place Avdel® speed fasteners (except 1/16" Avlug®) making it ideal for batch or flow-line assembly in a wide variety of applications throughout all industries.

The Hand Tool and Intensifier have been tested as separate items and combined. They must only be used together and for no other purposes. Refer to "Putting into Service" on page 8 for connection details.

Both models, the 07530 MkII and 07532 MkII are hand-held lightweight tools. Their only difference lies in the location of the hose entry. The top entry on the 07532 MkII tool allows suspension from an added mounting plate, see drawing opposite. Part numbers are shown to order a complete tool including the intensifier and all hoses but no nose equipment.

The pistol number for the 07530 MkII model is 07530-02200 and is 07532-02200 for the 07532 MkII model. See the general assemblies on pages 28-31.

Both models will place the same fasteners and both will place most repetition fasteners, as shown in the table below.

Both models make use of the same nose equipment. Reference must be made to the Nose Equipment section of the manual when selecting compatible components for the type and size of fastener used in your application (see pages 13-21). Nose jaw dimensions are shown on page 14.

FASTENER NAME	FASTENER SIZE											
	3/32"	1/8"	5/32"	3/16"	1/4"	2.5mm 2.8mm	3mm	3.5mm	4mm	6mm	M2.5 4-40 UNC	M3 6-32 UNC
CHOBERT®	●	●	●	●	●							
GROVIT®	●	●	●	●								
AVLUG®	●	●										
BRIV®	●	●	●	●						●		
RIVSCREW®						●	●	●	●			
AVTRONIC®						●						
AVSERT®											●	●

Intent of Use

Tool Dimensions - 07530 MkII Model

Part Number 07530-02100

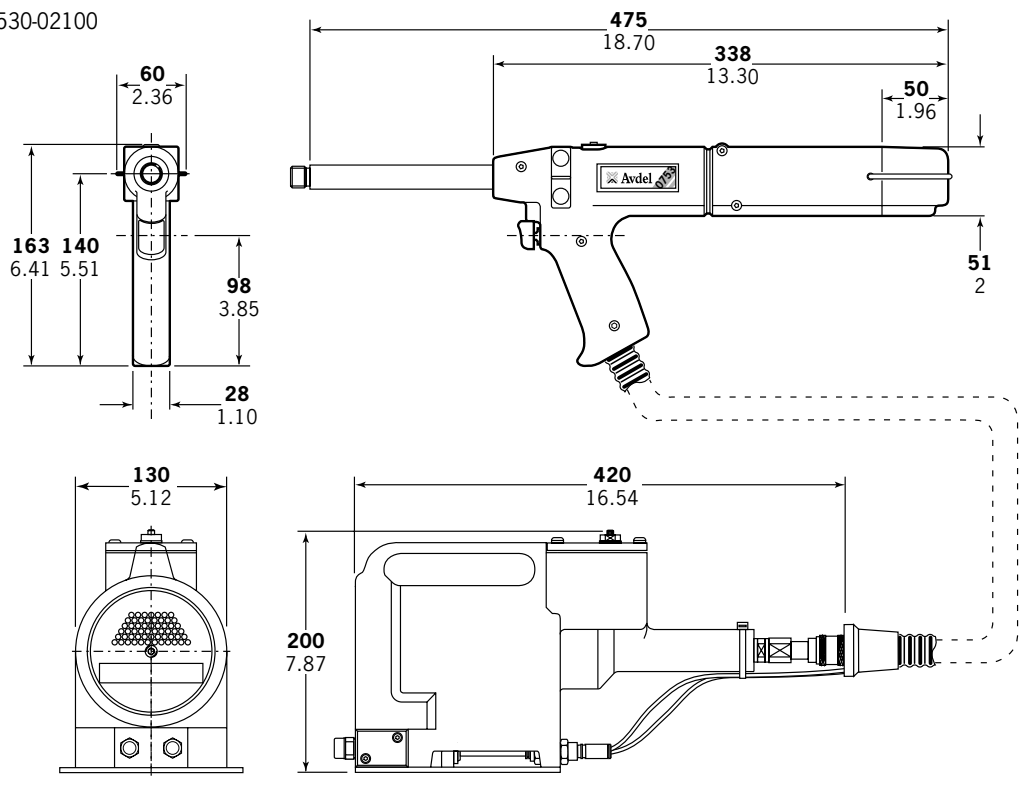

Tool Dimensions - 07532 MkII Model

Part Number 07532-02100

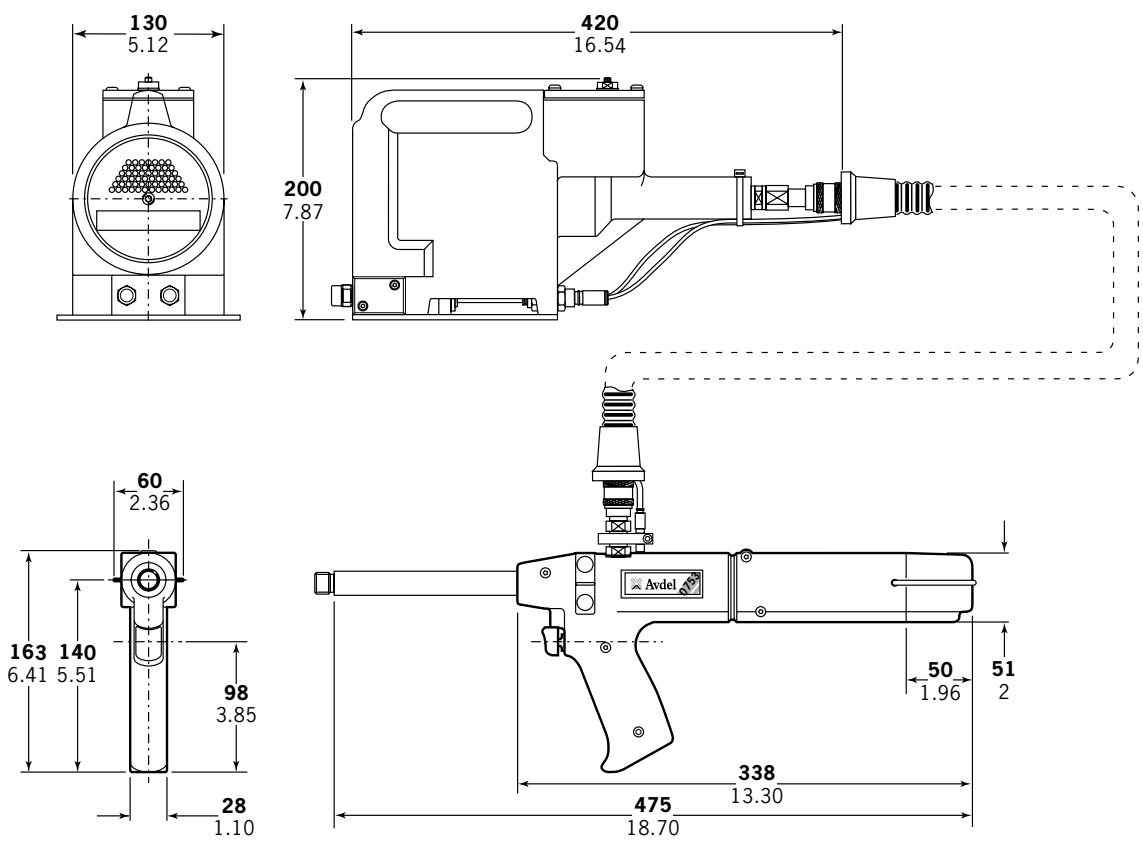

Dimensions shown in **bold** are millimetres. Other dimensions are in inches.

Putting into Service

Air Supply

All tools are operated with compressed air at an optimum pressure of 5.5 bar. We recommend the use of pressure regulators and automatic oiling/filtering systems on the main air supply. To ensure maximum tool life and minimum tool maintenance they should be fitted within 3 metres of the tool (see diagram below).

Air supply hoses should have a minimum working effective pressure rating of 150% of the maximum pressure produced in the system or 10 bar, whichever is the highest. Air hoses should be oil resistant, have an abrasion resistant exterior and should be armoured where operating conditions may result in hoses being damaged. All air supply hoses MUST have a minimum bore diameter of 6.4 millimetres or 1/4 inch.

Read daily servicing details page 22.

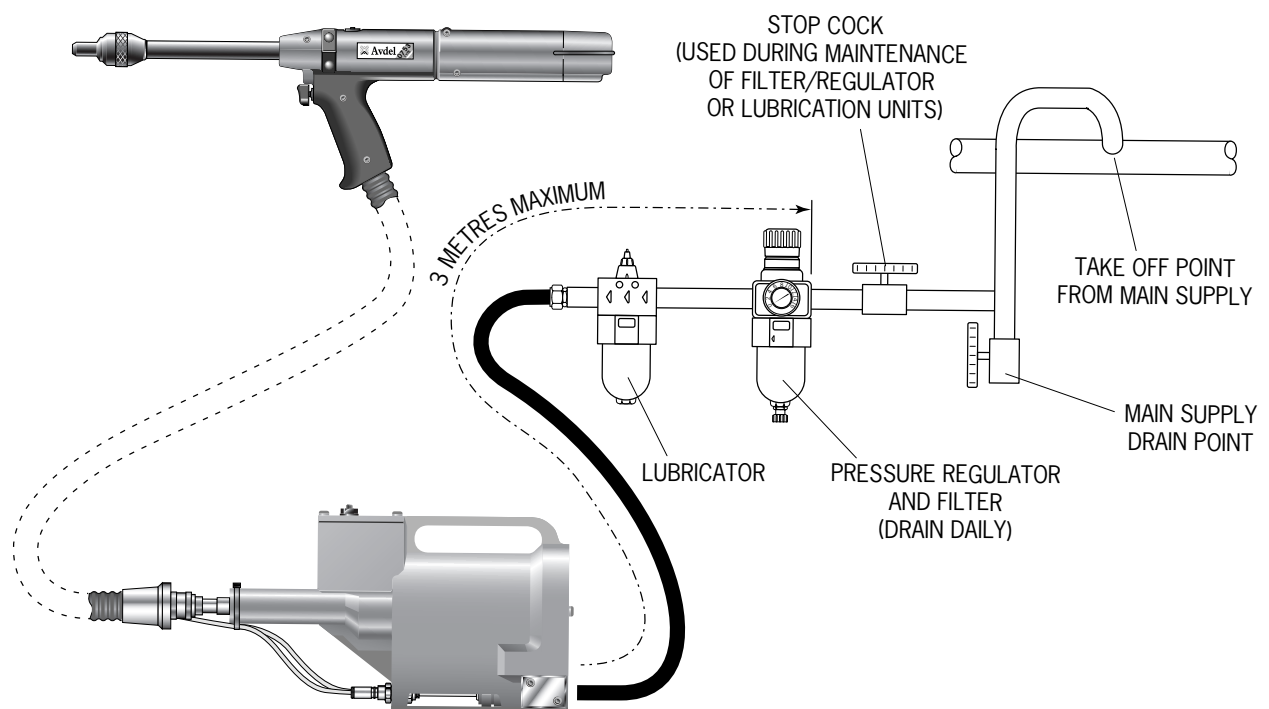

Follow the steps below when connecting the tool to the intensifier and main air supply:

- Push the end of the large hydraulic hose from the tool into the quick release connector on the end of the intensifier.
- On the front face of the intensifier:
 - Push the blue pneumatic (4mm OD) line into the reducer fitting which is located in the left hand bulkhead connector.
 - Push the black pneumatic (4mm OD) line into the plastic collet of the right hand bulkhead connector.
- Fit a pneumatic hose between the male connector at the rear of the intensifier and main air supply.

Putting into Service

Mechanical Cursors

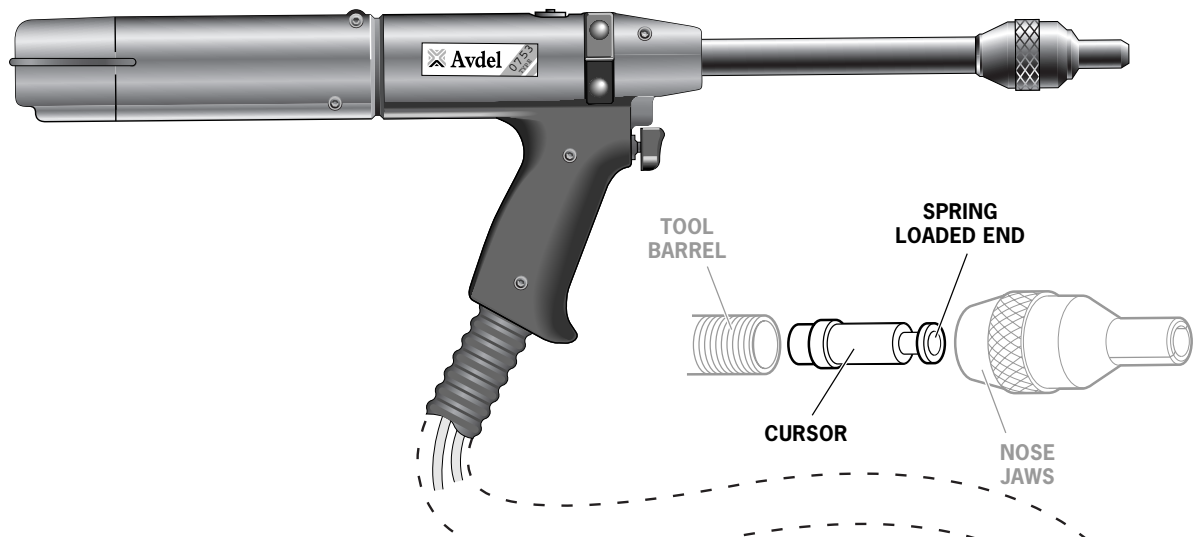

For reference there are three different mechanical cursor types:

- 07271-01100 Used for Standard mandrels and 5/32" Disposable mandrels
- 07279-05843 Used for 1/8" Disposable mandrels
- 07279-05845 Used for 3/16" Disposable mandrels

The difference in the above assemblies is the internal diameter of the End Plug.

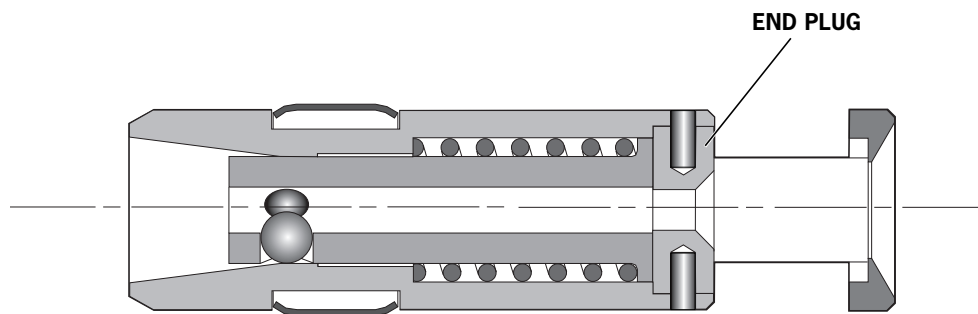

These are colour coded see below:

MECHANICAL CURSOR PART NO.	END PLUG PART NO.	COLOUR	HOLE DIAMETER (mm)
07271-01100	07150-00402	PLAIN STEEL	2.7
07279-05843	07159-05844	GOLD	2.2
07279-05845	07159-05846	SILVER	3.3

Putting into Service

Cursor

IMPORTANT

If fitted incorrectly, the cursor will not allow feeding of the fasteners.

While the cursor will be fitted the correct way round when the tool is supplied, we recommend that you check its orientation before fitting the nose equipment. The sprung loaded, slightly concave, end of the cursor should point towards the front of the tool as shown in the illustration.

When fitted the correct way round, the cursor will easily slide out of the barrel when a mandrel is pushed into its centre then pulled back.

To reverse the orientation of the cursor, follow these steps:

Item numbers in **bold** refer to the general assembly and parts list for the 07530-02200 MkII type on pages 28-29. For the 07532-02200 MkII type, the procedure is the same but the part numbers must be taken from the general assembly and parts list on pages 30-31.

- Remove the clip **47** and slide off end cap **38**.
- Using an Allen Key, remove one cap head screw **44** ensuring that any trapped air is exhausted. remove the second cap head screw **44**.
- Pull out rear plug **46**.
- Pull out tail jaw piston assembly **14** together with jaws **9**.
- Lift out spring **13** and jaw housing **8**.
- Insert a mandrel into the hole in the rear end of barrel **25** until it protrudes through the front of the barrel, then pull out the mandrel and cursor together through the front.
- Reassemble components in reverse order.
- Insert Mechanical Cursor Assembly **5** into the front of the barrel, correct way round.

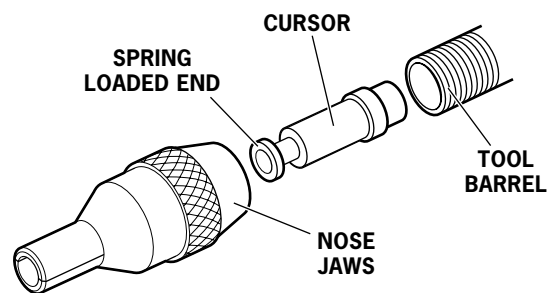

Loading and Reloading the Tool

IMPORTANT

The procedure for loading the tool and for fitting the nose equipment to the tool is integral.

When ordering a complete tool or system you will normally be supplied with all the nose equipment required for the fastener to be placed.

To identify nose equipment components or to select the correct elements, read the nose equipment section, on pages 13-21.

If you have been supplied with a nose jaw, mandrels and mandrel follower springs proceed with loading the tool and fitting the nose equipment as shown overleaf.

Item numbers in **bold** refer to the general assembly and parts list for the 07530-02200 MkII type on pages 28-29. For the 07532-02200 MkII type, the procedure is the same but the part numbers must be taken from the general assembly and parts list on pages 30-31.

Putting into Service

Loading the Tool

- Connect the air supply to the tool.
- Open tail jaws **9** which grip the mandrel, by switching off the tail jaw switch (items **26** and **30**).
- Screw selected nose jaws onto barrel **25** of the tool.
- Insert a mandrel into the tail end of the fasteners through the paper pod.
- Slide the mandrel follower spring onto the mandrel ensuring correct orientation, as shown in the table on page 12.
- Gripping the tail end of the mandrel, tear off the paper pod from around the fasteners.
- Open the nose jaws either by rotating the outer ring on Cam operated jaws or by pushing outwards on the jaw ends, as illustrated below left.
- Insert the previously assembled mandrel, mandrel follower spring and fasteners into the nose jaws until the first fastener to be placed is protruding from the nose jaw.
- Close the nose jaws and adjust so that the first fastener protrudes by 1.5mm - 3mm ($\frac{1}{16}''$ to $\frac{1}{8}''$), as shown in the illustration below right.
- Close the tail jaws to ensure the mandrel is gripped, by switching on the tail jaw switch (items **26** and **30**).

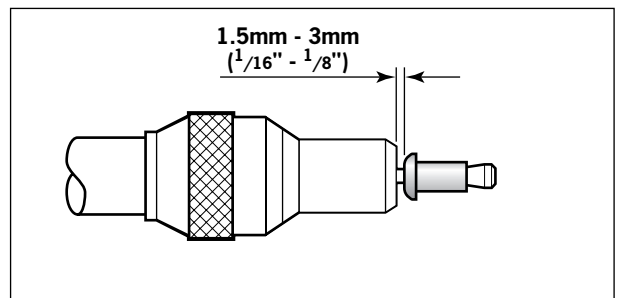
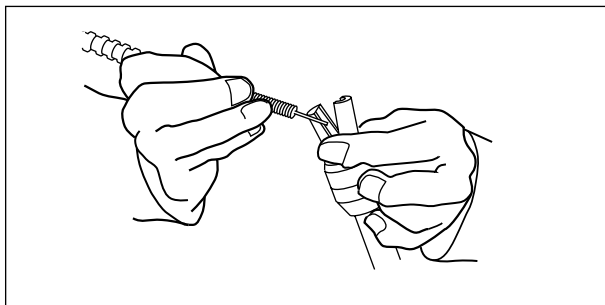

Reloading the Tool

- Open tail jaws **9** of tool.
- Open the nose jaws and pull the empty mandrel and mandrel follower spring out of the tool.
- Reload the tool by following the above instructions, starting at stage ■.

Operating Procedure

IMPORTANT

You must check that the cursor orientation and the nose equipment are correct before attempting to operate the tool.

- Push the fastener, protruding from the nose jaws, fully into the application holes ensuring that the tool is held square.
- Operate the trigger without releasing - the mandrel head is pulled through the fastener, forming the fastener into the application.
- Remove the tool.
- Release the trigger. The next fastener will be automatically presented through the nose jaws, ready for placing.

Item numbers in **bold** refer to the general assembly and parts list for the 07530-02200 MkII type on pages 28-29. For the 07532-02200 MkII type, the procedure is the same but the part numbers must be taken from the general assembly and parts list on pages 30-31.

Putting into Service

MANDREL FOLLOWER SPRINGS IDENTIFICATION AND ORIENTATION				
FASTENER		NOSE JAW (SEE NOSE EQUIPMENT SECTION)	MANDREL SIZE	MANDREL/MANDREL FOLLOWER SPRING AND FASTENER ASSEMBLY
NAME	SIZE			
BRIV®	3/32"	STANDARD TAPERED	ALL	
	3/32"	LIMITED ACCESS & LIMITED ACCESS CAM OPERATED	ALL	
	1/8"	ALL	ALL	
	5/32"	ALL	ALL	
	3/16"	ALL	ALL	
	6mm	STANDARD	ALL EXCEPT 3rd OVERSIZE	
CHOBERT® AVLUG® GROVIT®	3/32"	ALL EXCEPT STANDARD TAPERED, LIMITED ACCESS	ALL	
	3/32"	STANDARD TAPERED, LIMITED ACCESS	ALL	
	1/8"	ALL	ALL	
CHOBERT® GROVIT®	5/32"	ALL	ALL EXCEPT 3rd OVERSIZE	
	5/32"	ALL	3rd OVERSIZE	
	3/16"	ALL	ALL EXCEPT 2nd OVERSIZE	
	3/16"	ALL	2nd OVERSIZE	
CHOBERT®	1/4"	ALL	ALL	
RIVSCREW®	2.8mm	ALL	ALL	
	3mm			
	3.5mm			
	4mm			
AVSERT®	2.5mm	ALL	ALL	
	4 x 40 UNC	ALL	ALL	
	3mm			
AVTRONIC®	6 x 32 UNC	ALL	ALL	
	2.5mm	ALL	ALL	
	2.8mm	ALL EXCEPT LIMITED ACCESS	ALL	
	2.8mm	LIMITED ACCESS	ALL	

Nose Assemblies

On speed fastening tools such as 0753 MkII type, the nose equipment always consists of three elements: a nose jaw, a mandrel and a mandrel follower spring. All three items are matched to the fastener being placed and to the hole size in the application.

IMPORTANT

To avoid complete dismantling of the tool it is essential to check the orientation of the cursor before fitting the nose equipment to the tool. See 'CURSOR' section on page 10.

It is essential that the correct nose equipment is fitted to the tool to ensure both effective placing of the fastener and SAFE operation of the tool. READ THE SAFETY INSTRUCTIONS page 4 carefully.

To identify the correct combination of nose equipment to fit your tool first select a nose jaw by reading the section below then read the mandrel section to select part numbers both for the mandrel itself and for the mandrel follower spring. Mandrels and mandrel follower springs are illustrated on page 12.

To fit the nose equipment, follow the 'Loading the Tool' procedure page 11.

Nose Jaws

IMPORTANT

The wrong nose jaw could result in an incorrectly placed fastener or incorrect clench.

Nose Jaws can be categorised into 7 different basic shapes as illustrated opposite, even though internal dimensions will vary according to the fastener it is intended for. Exact dimensions referring to the letters in the illustrations opposite are indicated in the 'Nose Jaw Selection Tables' on pages 15-16.

For a particular shape, there may be several options of end form giving access benefits or fastener placing enhancement.

Flat

- Normal end form of all nose jaws.
- Suitable on all applications with no access restrictions.

Universal

- Designed for use with universal head Chobert® fasteners.
- Can also be used with Briv® fasteners to obtain the highest possible clench. Note this reduces the maximum grip range of the Briv® fastener by approximately 0.015" (0.4mm).

Recessed

- For use with Briv® fasteners ONLY.
- It gives a higher clench than a flat end form but less than a universal end form, with no reduction of the grip range of the fastener.

Tapered

- Available as shown in the 'Nose Jaw Selection Tables'.
- Allows greater accessibility than a flat end form and places the same range.

Head Forming

- For use with Rivscrew® fasteners ONLY.
- Deforms the head of the fastener to achieve good clench.

Nose Assemblies

Selecting a Nose Jaw

- List the name, size and material of the fastener to be placed.
- Look for this fastener in the first column of the nose jaw selection tables on page 15 if you use imperial measurements and on page 16 if you use metric units.
- Looking right across the table, take note of which nose jaws are available. ONLY those shown are available.
- Select which is most suitable for your application by referring to the respective nose jaw drawing. If your application has no access restriction, you should select the standard shape with a flat end form with or without a cam.

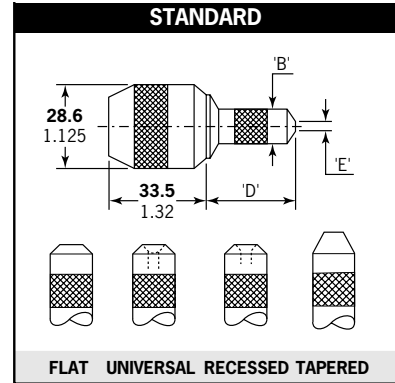

Available in 4 different end forms to place all fasteners (except Rivscrew). Suitable on applications with no or little access restriction.

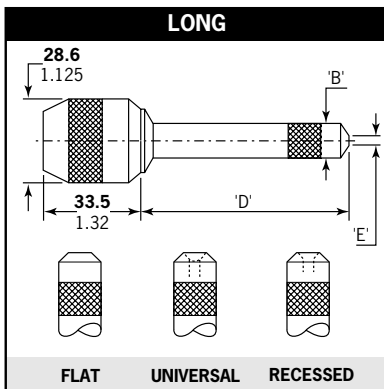

Available to place most of the fasteners. Allows more penetration into applications with no other access restriction.

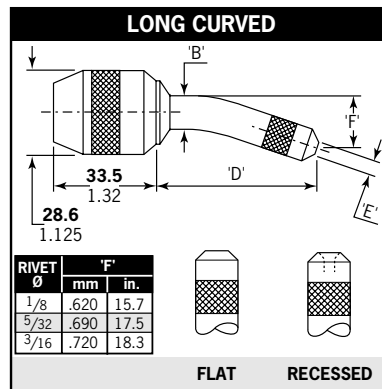

Available as shown in NOSE JAW SELECTION TABLE. Allows more penetration into applications with restricted access. Mandrels must be curved by hand to follow the shape of the jaw.

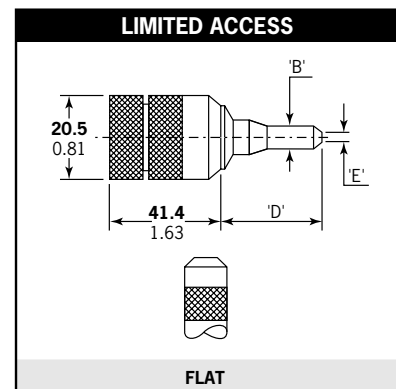

Available as shown in NOSE JAW SELECTION TABLE. Allows access into very restrictive applications.

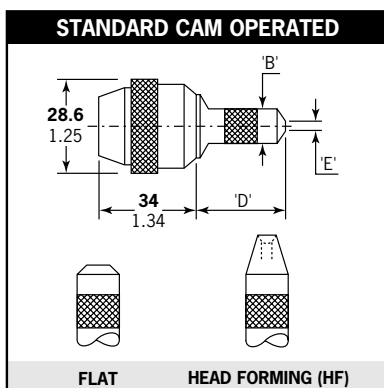

Available as shown in NOSE JAW SELECTION TABLE overleaf. Equivalent functions to the Standard and Limited Access above with the addition of a cam to ease and speed up the nose jaw opening thus the pod reloading procedure.

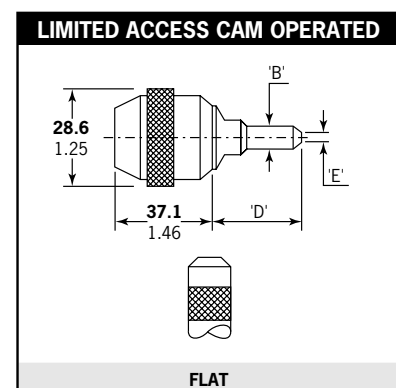
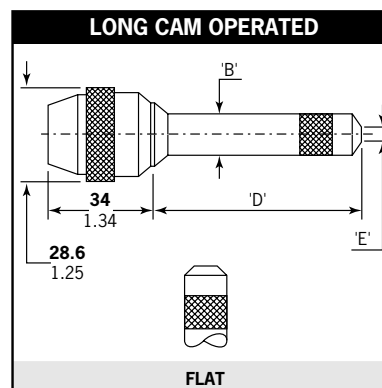

Dimensions shown in **bold** are millimetres. Other dimensions are in inches.

Nose Assemblies

Nose Jaw Selection - Imperial

The 'REF N°' column cross references with the 'REF N°' columns in the mandrel section. It identifies both the mandrel and mandrel follower spring required for a particular nose jaw with a specific fastener.

FASTENER	REF. N°	NOSE JAW				REF. N°	NOSE JAW					
		TYPE AND END FORM	PART N°	DIMENSIONS			TYPE AND END FORM	PART N°	DIMENSIONS			
				'B'	'D'	'E'				'B'	'D'	'E'
3/32" CHOBERT® & GROVIT	1	STANDARD - FLAT	07150-03003	.36	1.30	.16	1	# STANDARD - UNIVERSAL	07150-03203	.36	1.33	.24
	1	STD. CAM OPERATED - FLAT	07170-04500	.36	1.30	.16	1	LTD. ACCESS CAM OPERATED	07177-03003	.20	1.18	.16
	2	STANDARD - TAPERED	07170-03103	.36	1.30	.16	3	LIMITED ACCESS	07274-01000	.22	1.07	.16
	4	LONG - FLAT	07150-04003	.41	2.30	.16	4	LONG CURVED - FLAT	07150-05003	.41	2.28	.16
1/8" CHOBERT® & GROVIT	5	STANDARD - FLAT	07150-03004	.41	1.18	.20	5	# STANDARD - UNIVERSAL	07150-03204	.41	1.22	.32
	5	STANDARD - TAPERED	07170-03104	.41	1.19	.20	5	STD. CAM OPERATED - FLAT	07170-04600	.41	1.18	.20
	6	LONG - FLAT	07150-04004	.41	2.18	.20	6	# LONG - UNIVERSAL	07150-04204	.41	2.22	.30
	6	LONG CURVED - FLAT	07150-05004	.41	2.12	.20	6	LONG CAM OPERATED - FLAT	07170-05000	.41	2.18	.20
5/32" CHOBERT® & GROVIT	7	STANDARD - FLAT	07150-03005	.48	1.30	.24	7	# STANDARD - UNIVERSAL	07150-03205	.48	1.35	.41
	7	STANDARD - TAPERED	07150-03105	.44	1.30	.24	7	STD. CAM OPERATED - FLAT	07170-04700	.48	1.30	.24
	8	LONG - FLAT	07150-04005	.48	2.30	.24	8	# LONG - UNIVERSAL	07150-04205	.48	2.35	.42
	8	LONG CURVED - FLAT	07150-05005	.48	2.23	.24	8	LONG CAM OPERATED - FLAT	07170-05100	.48	2.30	.24
3/16" CHOBERT® & GROVIT	9	STANDARD - FLAT	07150-03006	.56	1.18	.33	9	# STANDARD - UNIVERSAL	07150-03206	.56	1.24	.47
	9	STANDARD - TAPERED	07150-03106	.56	1.18	.33	9	STD. CAM OPERATED - FLAT	07170-04800	.56	1.18	.33
	10	LONG - FLAT	07150-04006	.56	2.30	.33	10	# LONG - UNIVERSAL	07150-04206	.56	2.39	.48
	10	LONG CURVED - FLAT	07150-05006	.56	2.21	.33	10	LONG CAM OPERATED - FLAT	07170-05200	.56	2.30	.33
1/4" CHOBERT®	11	STANDARD - FLAT	07150-03008	.64	1.18	.39	11	STD. CAM OPERATED - FLAT	07170-04900	.64	1.18	.39
	12	LONG - FLAT	07150-04008	.64	2.18	.39	12	LONG CAM OPERATED - FLAT	07170-05300	.64	2.18	.39
3/32" BRIV® Brass only	13	STANDARD - TAPERED	07170-03103	.36	1.30	.15	14	LTD. ACCESS CAM OPERATED	07177-03003	.20	1.18	.16
	14	LIMITED ACCESS	07274-01000	.22	1.07	.16	-	-	-	-	-	-
1/8" BRIV® Al. Alloy, Brass, Steel	15	STANDARD - FLAT	07150-03004	.41	1.18	.20	15	STANDARD - RECESSED	07170-03004	.41	1.20	.30
	15	STANDARD - TAPERED	07170-03104	.41	1.19	.20	16	LONG - FLAT	07150-04004	.41	2.18	.20
	16	LONG - RECESSED	07170-03204	.41	2.18	.30	16	LONG CURVED - FLAT	07150-05004	.41	2.12	.20
	16	LONG CURVED - RECESSED	07170-03304	.41	2.12	.30	-	-	-	-	-	-
5/32" BRIV® Al. Alloy, Brass, Steel	17	STANDARD - FLAT	07150-03005	.48	1.30	.24	17	STANDARD - RECESSED	07170-03005	.48	1.32	.41
	18	LONG - FLAT	07150-04005	.48	2.30	.24	18	LONG - RECESSED	07170-03205	.48	2.30	.41
	18	LONG CURVED - FLAT	07150-05005	.48	2.23	.24	18	LONG CURVED - RECESSED	07170-03305	.48	2.23	.41
5/32" BRIV® St. Steel only	19	STANDARD - FLAT	07150-03005	.48	1.30	.24	19	STANDARD - RECESSED	07170-03005	.48	1.32	.41
	20	LONG - FLAT	07150-04005	.48	2.30	.24	20	LONG - RECESSED	07170-03205	.48	2.30	.41
	20	LONG CURVED - FLAT	07150-05005	.48	2.23	.24	20	LONG CURVED - RECESSED	07170-03305	.48	2.23	.41
3/16" BRIV® Al. Alloy, Brass, Steel	21	STANDARD - FLAT	07150-03006	.56	1.18	.33	21	STANDARD - RECESSED	07170-03006	.56	1.20	.47
	22	LONG - FLAT	07150-04006	.56	2.30	.33	22	LONG - RECESSED	07170-03206	.56	2.30	.47
	22	LONG CURVED - FLAT	07150-05006	.56	2.21	.33	22	LONG CURVED - RECESSED	07170-03306	.56	2.21	.47
3/16" BRIV® St. Steel only	23	STANDARD - FLAT	07150-03006	.56	1.18	.33	23	STANDARD - RECESSED	07170-03006	.56	1.20	.47
	24	LONG - FLAT	07150-04006	.56	2.30	.33	24	LONG - RECESSED	07170-03206	.56	2.30	.47
	24	LONG CURVED - FLAT	07150-05006	.56	2.21	.33	24	LONG CURVED - RECESSED	07170-03306	.56	2.21	.47
6mm BRIV® Al. Alloy, Steel	25	STD. CAM OPERATED	07170-05600	.64	1.21	.52	25	STANDARD - FLAT	07170-05800	.64	1.21	.52
	26	LONG CAM OPERATED	07170-05700	.64	2.19	.52	26	LONG - FLAT	07170-05900	.64	2.19	.52
3/32" AVLUG®	27	STANDARD - FLAT	07150-03003	.36	1.30	.16	27	STANDARD - TAPERED	07150-03103	.36	1.30	.16
	27	STD. CAM OPERATED - FLAT	07170-04500	.36	1.30	.16	28	LONG - FLAT	07150-04003	.41	2.30	.16
	28	LONG CURVED - FLAT	07150-05003	.41	2.28	.16	-	-	-	-	-	-
1/8" AVLUG®	29	STANDARD - FLAT	07150-03004	.41	1.18	.20	29	STANDARD - TAPERED	07170-03104	.41	1.19	.20
	29	STD. CAM OPERATED - FLAT	07170-04600	.41	1.18	.20	30	LONG - FLAT	07150-04004	.41	2.18	.20
	30	LONG CURVED - FLAT	07150-05004	.41	2.12	.20	30	LONG CAM OPERATED - FLAT	07170-05000	.41	2.18	.20
2.5mm, 4-40 UNC AVSERT®	31	STANDARD - FLAT	07150-03003	.36	1.30	.16	-	-	-	-	-	-
3.0mm, 6-32 UNC AVSERT®	32	STANDARD - FLAT	07150-03004	.41	1.18	.20	32	STD. CAM OPERATED - FLAT	07170-04600	.41	1.18	.20
2.5mm AVTRONIC®	33	STANDARD - FLAT	07150-03003	.36	1.30	.16	33	LTD. ACCESS CAM OPERATED	07271-08000	.41	1.18	.16
	34	LONG - FLAT	07150-04003	.41	2.30	.16	-	-	-	-	-	-
2.8mm AVTRONIC®	35	STANDARD - FLAT	07271-05600	.36	1.30	.16	36	LTD. ACCESS CAM OPERATED	07271-08100	.40	1.18	.16
	37	LONG - FLAT	07271-05900	.41	2.30	.16	-	-	-	-	-	-
2.8mm RIVSCREW®	38	STD. CAM OPERATED - HF	07271-03000	.41	1.18	.24	-	-	-	-	-	-
3.0mm RIVSCREW®	39	STD. CAM OPERATED - HF	07271-03000	.41	1.18	.24	-	-	-	-	-	-
3.5mm RIVSCREW®	40	STD. CAM OPERATED - HF	07271-03500	.41	1.18	.24	-	-	-	-	-	-
4.0mm RIVSCREW®	41	STD. CAM OPERATED - HF	07271-04000	.41	1.18	.25	-	-	-	-	-	-

These nose jaws are suitable for placing Chobert® rivets with a Universal Head Form. When used on the equivalent size of Briv®, the highest possible clench is achieved. Note when using Briv® fasteners, the maximum grip is reduced by approximately 0.015" (0.4mm). possible clench is achieved. Note that when using Briv fasteners, the maximum grip is reduced by approximately 0.015" (0.4 mm).

Nose Assemblies

Nose Jaw Selection - Metric

FASTENER	REF. N°	NOSE JAW					REF. N°	NOSE JAW				
		TYPE AND END FORM	PART N°	DIMENSIONS				TYPE AND END FORM	PART N°	DIMENSIONS		
				'B'	'D'	'E'				'B'	'D'	'E'
3/32" CHOBERT® & GROVIT	1	STANDARD - FLAT	07150-03003	9.14	33.02	4.06	1	# STANDARD - UNIVERSAL	07150-03203	9.14	33.78	6.10
	1	STD. CAM OPERATED - FLAT	07170-04500	9.14	33.02	4.06	1	LTD. ACCESS CAM OPERATED	07177-03003	5.08	29.97	4.06
	2	STANDARD - TAPERED	07170-03103	9.14	33.02	4.06	3	LIMITED ACCESS	07274-01000	5.59	27.18	4.06
	4	LONG - FLAT	07150-04003	10.41	58.42	4.06	4	LONG CURVED - FLAT	07150-05003	10.41	57.91	4.06
1/8" CHOBERT® & GROVIT	5	STANDARD - FLAT	07150-03004	10.41	29.97	5.08	5	# STANDARD - UNIVERSAL	07150-03204	10.41	30.99	8.13
	5	STANDARD - TAPERED	07170-03104	10.41	30.23	5.08	5	STD. CAM OPERATED - FLAT	07170-04600	10.41	29.97	5.08
	6	LONG - FLAT	07150-04004	10.41	55.37	5.08	6	# LONG - UNIVERSAL	07150-04204	10.41	56.39	7.62
	6	LONG CURVED - FLAT	07150-05004	10.41	53.85	5.08	6	LONG CAM OPERATED - FLAT	07170-05000	10.41	55.37	5.08
5/32" CHOBERT® & GROVIT	7	STANDARD - FLAT	07150-03005	12.19	33.02	6.10	7	# STANDARD - UNIVERSAL	07150-03205	12.19	34.29	10.41
	7	STANDARD - TAPERED	07150-03105	11.18	33.02	6.10	7	STD. CAM OPERATED - FLAT	07170-04700	12.19	33.02	6.10
	8	LONG - FLAT	07150-04005	12.19	58.42	6.10	8	# LONG - UNIVERSAL	07150-04205	12.19	59.69	10.67
	8	LONG CURVED - FLAT	07150-05005	12.19	56.64	6.10	8	LONG CAM OPERATED - FLAT	07170-05100	12.19	58.42	6.10
3/16" CHOBERT® & GROVIT	9	STANDARD - FLAT	07150-03006	14.22	29.97	8.38	9	# STANDARD - UNIVERSAL	07150-03206	14.22	31.50	11.94
	9	STANDARD - TAPERED	07150-03106	14.22	29.97	8.38	9	STD. CAM OPERATED - FLAT	07170-04800	14.22	29.97	8.38
	10	LONG - FLAT	07150-04006	14.22	58.42	8.38	10	# LONG - UNIVERSAL	07150-04206	14.22	60.71	12.19
	10	LONG CURVED - FLAT	07150-05006	14.22	56.13	8.38	10	LONG CAM OPERATED - FLAT	07170-05200	14.22	58.42	8.38
1/4" CHOBERT®	11	STANDARD - FLAT	07150-03008	16.26	29.97	9.91	11	STD. CAM OPERATED - FLAT	07170-04900	16.26	29.97	9.91
	12	LONG - FLAT	07150-04008	16.26	55.37	9.91	12	LONG CAM OPERATED - FLAT	07170-05300	16.26	55.37	9.91
3/32" BRIV® Brass only	13	STANDARD - TAPERED	07170-03103	9.14	33.02	3.81	14	LTD. ACCESS CAM OPERATED	07177-03003	5.08	29.97	4.06
	14	LIMITED ACCESS	07274-01000	5.59	27.18	4.06	-	-	-	-	-	-
1/8" BRIV® Al. Alloy, Brass, Steel	15	STANDARD - FLAT	07150-03004	10.41	29.97	5.08	15	STANDARD - RECESSED	07170-03004	10.41	30.48	7.62
	15	STANDARD - TAPERED	07170-03104	10.41	30.23	5.08	16	LONG - FLAT	07150-04004	10.41	55.37	5.08
	16	LONG - RECESSED	07170-03204	10.41	55.37	7.62	16	LONG CURVED - FLAT	07150-05004	10.41	53.85	5.08
	16	LONG CURVED - RECESSED	07170-03304	10.41	53.85	7.62	-	-	-	-	-	-
5/32" BRIV® Al. Alloy, Brass, Steel	17	STANDARD - FLAT	07150-03005	12.19	33.02	6.10	17	STANDARD - RECESSED	07170-03005	12.19	33.53	10.41
	18	LONG - FLAT	07150-04005	12.19	58.42	6.10	18	LONG - RECESSED	07170-03205	12.19	58.42	10.41
	18	LONG CURVED - FLAT	07150-05005	12.19	56.64	6.10	18	LONG CURVED - RECESSED	07170-03305	12.19	56.64	10.41
5/32" BRIV® St. Steel only	19	STANDARD - FLAT	07150-03005	12.19	33.02	6.10	19	STANDARD - RECESSED	07170-03005	12.19	33.53	10.41
	20	LONG - FLAT	07150-04005	12.19	58.42	6.10	20	LONG - RECESSED	07170-03205	12.19	58.42	10.41
	20	LONG CURVED - FLAT	07150-05005	12.19	56.64	6.10	20	LONG CURVED - RECESSED	07170-03305	12.19	56.64	10.41
3/16" BRIV® Al. Alloy, Brass, Steel	21	STANDARD - FLAT	07150-03006	14.22	29.97	8.38	21	STANDARD - RECESSED	07170-03006	14.22	30.48	11.94
	22	LONG - FLAT	07150-04006	14.22	58.42	8.38	22	LONG - RECESSED	07170-03206	14.22	58.42	11.94
	22	LONG CURVED - FLAT	07150-05006	14.22	56.13	8.38	22	LONG CURVED - RECESSED	07170-03306	14.22	56.13	11.94
3/16" BRIV® St. Steel only	23	STANDARD - FLAT	07150-03006	14.22	29.97	8.38	23	STANDARD - RECESSED	07170-03006	14.22	30.48	11.94
	24	LONG - FLAT	07150-04006	14.22	58.42	8.38	24	LONG - RECESSED	07170-03206	14.22	58.42	11.94
	24	LONG CURVED - FLAT	07150-05006	14.22	56.13	8.38	24	LONG CURVED - RECESSED	07170-03306	14.22	56.13	11.94
6mm BRIV® Al. Alloy, Steel	25	STD. CAM OPERATED	07170-05600	16.33	30.65	13.14	25	STANDARD - FLAT	07170-05800	16.33	30.65	13.14
	26	LONG CAM OPERATED	07170-05700	16.33	55.65	13.14	26	LONG - FLAT	07170-05900	16.33	55.65	13.14
3/32" AVLUG®	27	STANDARD - FLAT	07150-03003	9.14	33.02	4.06	27	STANDARD - TAPERED	07150-03103	9.14	33.02	4.06
	27	STD. CAM OPERATED - FLAT	07170-04500	9.14	33.02	4.06	28	LONG - FLAT	07150-04003	10.41	58.42	4.06
	28	LONG CURVED - FLAT	07150-05003	10.41	57.91	4.06	-	-	-	-	-	-
1/8" AVLUG®	29	STANDARD - FLAT	07150-03004	10.41	29.97	5.08	29	STANDARD - TAPERED	07170-03104	10.41	30.23	5.08
	29	STD. CAM OPERATED - FLAT	07170-04600	10.41	29.97	5.08	30	LONG - FLAT	07150-04004	10.41	55.37	5.08
	30	LONG CURVED - FLAT	07150-05004	10.41	53.85	5.08	30	LONG CAM OPERATED - FLAT	07170-05000	10.41	55.37	5.08
2.5mm, 4-40 UNC AVSERT®	31	STANDARD - FLAT	07150-03003	9.14	33.02	4.06	-	-	-	-	-	-
3.0mm, 6-32 UNC AVSERT®	32	STANDARD - FLAT	07150-03004	10.41	29.97	5.08	32	STD. CAM OPERATED - FLAT	07170-04600	10.41	29.97	5.08
2.5mm AVTRONIC®	33	STANDARD - FLAT	07150-03003	9.14	33.02	4.06	33	LTD. ACCESS CAM OPERATED	07271-08000	10.41	29.97	4.06
	34	LONG - FLAT	07150-04003	10.41	58.42	4.06	-	-	-	-	-	-
2.8mm AVTRONIC®	35	STANDARD - FLAT	07271-05600	9.14	33.02	4.06	36	LTD. ACCESS CAM OPERATED	07271-08100	10.16	29.97	4.06
	37	LONG - FLAT	07271-05900	10.41	58.42	4.06	-	-	-	-	-	-
2.8mm RIVSCREW®	38	STD. CAM OPERATED - HF	07271-03000	10.41	29.97	6.10	-	-	-	-	-	-
3.0mm RIVSCREW®	39	STD. CAM OPERATED - HF	07271-03000	10.41	29.97	6.10	-	-	-	-	-	-
3.5mm RIVSCREW®	40	STD. CAM OPERATED - HF	07271-03500	10.41	29.97	6.10	-	-	-	-	-	-
4.0mm RIVSCREW®	41	STD. CAM OPERATED - HF	07271-04000	10.41	29.97	6.35	-	-	-	-	-	-

These nose jaws are suitable for placing Chobert® rivets with a Universal Head Form. When used on the equivalent size of Briv®, the highest possible clench is achieved. Note that when using Briv® fasteners, the maximum grip is reduced by approximately 0.015" (0.4mm). possible clench is achieved. Note that when using Briv fasteners, the maximum grip is reduced by approximately 0.015" (0.4 mm).

Nose Assemblies

Mandrels and Mandrel Follower Springs

Mandrels and mandrel follower springs, illustrated on page 12 need to be selected to suit the fastener type and size as well as the size of the hole in the application. Use of the wrong mandrel could increase the risk of breakage and the wear of the mandrel head. Feeding problems could occur if the wrong mandrel follower spring is used.

IMPORTANT

READ THE SAFETY INSTRUCTIONS page 4 carefully.

While a small amount of wear and marking will naturally occur through normal and correct use of mandrels, they must be regularly examined for excessive wear and marking, with particular attention to the head diameter, the tail jaw gripping area of the shank or heavy pitting of the shank and any mandrel distortion. Mandrels which fail during use could forcibly exit the tool. It is the customer's responsibility to ensure that mandrels are replaced before any excessive levels of wear and always before the maximum recommended number of placings. Contact your Avdel representative who will let you know what that figure is by measuring the broach load of your application with our calibrated measuring tool. These tools can also be purchased under part number 07900-09080, supplied with all necessary information for testing.

Chobert® and Grovit® - Imperial

For mandrel or mandrel follower spring selection, follow instructions on page 19.

FASTENER	REF. N°	HOLE SIZE	STANDARD MANDREL - GREEN					HOLE SIZE	1ST OVERSIZE MANDREL - YELLOW					SPRING PART N°
			HEAD Ø	MANDREL PART N°	P MAX.	# S/R MANDREL PART N°	P MAX.		HEAD Ø	MANDREL PART N°	P MAX.	# S/R MANDREL PART N°	P MAX.	
3/32" CHOBERT® & GROVIT®	1	AS REC.	.0725	07150-06003	.166	07150-08003	.071	+0.015	.074	07150-06303	.174	-	-	07150-06803
	1	-	-	-	-	-	-	+0.035	.076	-	-	07150-08103	.078	07150-06803
	2	AS REC.	.0725	07150-06003	.166	07150-08003	.071	+0.015	.074	07150-06303	.174	-	-	07170-06873
	2	-	-	-	-	-	-	+0.035	.076	-	-	07150-08103	.078	07170-06873
	3	AS REC.	.0725	07150-06003	.166	07150-08003	.071	+0.015	.074	07150-06303	.174	-	-	07170-06903
	3	-	-	-	-	-	-	+0.035	.076	-	-	07150-08103	.078	07170-06903
	4	AS REC.	.0725	07150-07003	.166	07150-09003	.071	+0.035	.076	-	-	07150-09103	.078	07150-07803
	4	-	-	-	-	-	-	-	-	-	-	-	-	-
1/8" CHOBERT® & GROVIT®	5	AS REC.	.088	07150-06004	.216	07150-08004	.090	+0.04	.092	07150-06104	.237	07150-08104	.098	07150-06804
	6	AS REC.	.088	07150-07004	.216	07150-09004	.090	+0.04	.092	07150-07104	.237	07150-09104	.098	07150-07804
5/32" CHOBERT® & GROVIT®	7	AS REC.	.107	07150-06005	.244	07150-08005	.100	+0.08	.115	07150-06105	.284	07150-08105	.116	07170-06875
	7	-	-	-	-	-	-	-	-	-	-	-	-	
	8	AS REC.	.107	07150-07005	.244	07150-09005	.100	+0.08	.115	07150-07105	.284	07150-09105	.116	07170-07875
	8	-	-	-	-	-	-	-	-	-	-	-	-	
3/16" CHOBERT® & GROVIT®	9	AS REC.	.132	07150-06006	.247	07150-08006	.102	+0.14	.146	07150-06106	.320	07150-08106	.130	07170-06876
	9	-	-	-	-	-	-	-	-	-	-	-	-	
	10	AS REC.	.132	07150-07006	.247	07150-09006	.102	+0.14	.146	07150-07106	.320	07150-09106	.130	07170-07876
	10	-	-	-	-	-	-	-	-	-	-	-	-	
1/4" CHOBERT®	11	AS REC.	.184	07150-06008	.268	07150-08008	.110	+0.12	.196	07150-06108	.330	07150-08108	.134	07150-06808
	12	AS REC.	.184	07150-07008	.268	07150-09008	.110	+0.12	.196	07150-07108	.330	07150-09108	.134	07150-07808

FASTENER	REF. N°	HOLE SIZE	2ND OVERSIZE MANDREL - BLUE					HOLE SIZE	3RD OVERSIZE MANDREL - RED					SPRING PART N°
			HEAD Ø	MANDREL PART N°	P MAX.	# S/R MANDREL PART N°	P MAX.		HEAD Ø	MANDREL PART N°	P MAX.	# S/R MANDREL PART N°	P MAX.	
3/32" CHOBERT® & GROVIT®	1	+0.035	.076	07150-06103	.185	-	-	-	-	-	-	-	-	07150-06803
	1	-	-	-	-	-	-	-	-	-	-	-	-	-
	2	+0.035	.076	07150-06103	.185	-	-	-	-	-	-	-	-	07170-06873
	2	-	-	-	-	-	-	-	-	-	-	-	-	-
	3	+0.035	.076	07150-06103	.185	-	-	-	-	-	-	-	-	07170-06903
	3	-	-	-	-	-	-	-	-	-	-	-	-	-
1/8" CHOBERT® & GROVIT®	5	+0.10	.098	07150-06204	.268	07150-08204	.110	+0.14	.102	07150-06304	.288	07150-08304	.118	07150-06804
	6	+0.10	.098	07150-07204	.268	07150-09204	.110	+0.14	.102	07150-07304	.288	07150-09304	.118	07150-07804
5/32" CHOBERT® & GROVIT®	7	+0.15	.122	07150-06205	.320	07150-08205	.130	-	-	-	-	-	-	07170-06875
	7	-	-	-	-	-	-	+0.025	.132	07150-06305	.372	07150-08305	.150	07150-06805
	8	+0.15	.122	07150-07205	.320	07150-09205	.130	-	-	-	-	-	-	07170-07875
	8	-	-	-	-	-	-	+0.025	.132	07150-07305	.372	07150-09305	.150	07150-07805
3/16" CHOBERT® & GROVIT®	9	-	-	-	-	-	-	-	-	-	-	-	-	-
	9	+0.24	.156	07150-06206	.372	07150-08206	.150	-	-	-	-	-	-	07150-06806
	10	-	-	-	-	-	-	-	-	-	-	-	-	-
1/4" CHOBERT®	11	-	-	-	-	-	-	-	-	-	-	-	-	-
	12	-	-	-	-	-	-	-	-	-	-	-	-	-

S/R: Short Reach Mandrel. See page 19-20 for explanation.

Nose Assemblies

Tables below left and right and over the next four pages list part numbers of all mandrels and mandrel follower springs available per fastener or group of fasteners, i.e. for Chobert® and Grovit® on these pages.

While fastener sizes are always shown in their specified units, each table has been produced twice to offer dimensions in imperial units on the left-hand page then in metric units on the right-hand page. These 'Mandrel Selection' tables cross-reference with the 'Nose Jaw Selection' tables on pages 15-16 through the 'Ref. N°' column.

It is the diameter of the head at the end of a mandrel which when pulled through controls the expansion of the fastener body.

While there are different head shapes to suit different types of fasteners (see illustration on page 20), progressive head sizes are needed to reflect manufacturing tolerances on the diameter of the hole in your application so that the fastener always expands sufficiently to fill the hole.

Too large a mandrel head would overstress the mandrel and mandrels which fail during use could forcibly exit the tool.

Selection tables are arranged into four 'mandrel size' sections, ranging from 'standard' to '3rd oversize', each being colour coded as per the end of the mandrel heads themselves.

Chobert® and Grovit® - Metric

FASTENER	REF. N°	HOLE SIZE	STANDARD MANDREL - GREEN					HOLE SIZE	1ST OVERSIZE MANDREL - YELLOW					SPRING PART N°
			HEAD Ø	MANDREL PART N°	P MAX.	# S/R MANDREL PART N°	P MAX.		HEAD Ø	MANDREL PART N°	P MAX.	# S/R MANDREL PART N°	P MAX.	
3/32" CHOBERT® & GROVIT®	1	AS REC.	1.84	07150-06003	4.22	07150-08003	1.80	+04	1.88	07150-06303	4.42	-	-	07150-06803
	1	-	-	-	-	-	-	+09	1.93	-	-	07150-08103	1.98	07150-06803
	2	AS REC.	1.84	07150-06003	4.22	07150-08003	1.80	+04	1.88	07150-06303	4.42	-	-	07170-06873
	2	-	-	-	-	-	-	+09	1.93	-	-	07150-08103	1.98	07170-06873
	3	AS REC.	1.84	07150-06003	4.22	07150-08003	1.80	+04	1.88	07150-06303	4.42	-	-	07170-06903
	3	-	-	-	-	-	-	+09	1.93	-	-	07150-08103	1.98	07170-06903
	4	AS REC.	1.84	07150-07003	4.22	07150-09003	1.80	+09	1.93	-	-	07150-09103	1.98	07150-07803
	4	-	-	-	-	-	-	-	-	-	-	-	-	-
1/8" CHOBERT® & GROVIT®	5	AS REC.	2.24	07150-06004	5.49	07150-08004	2.29	+10	2.34	07150-06104	6.02	07150-08104	2.49	07150-06804
	6	AS REC.	2.24	07150-07004	5.49	07150-09004	2.29	+10	2.34	07150-07104	6.02	07150-09104	2.49	07150-07804
5/32" CHOBERT® & GROVIT®	7	AS REC.	2.72	07150-06005	6.20	07150-08005	2.54	+20	2.92	07150-06105	7.21	07150-08105	2.95	07170-06875
	7	-	-	-	-	-	-	-	-	-	-	-	-	-
	8	AS REC.	2.72	07150-07005	6.20	07150-09005	2.54	+20	2.92	07150-07105	7.21	07150-09105	2.95	07170-07875
3/16" CHOBERT® & GROVIT®	9	AS REC.	3.35	07150-06006	6.27	07150-08006	2.59	+35	3.71	07150-06106	8.13	07150-08106	3.30	07170-06876
	9	-	-	-	-	-	-	-	-	-	-	-	-	-
	10	AS REC.	3.35	07150-07006	6.27	07150-09006	2.59	+35	3.71	07150-07106	8.13	07150-09106	3.30	07170-07876
1/4" CHOBERT®	11	AS REC.	4.67	07150-06008	6.81	07150-08008	2.79	+30	4.98	07150-06108	8.38	07150-08108	3.40	07150-06808
	12	AS REC.	4.67	07150-07008	6.81	07150-09008	2.79	+30	4.98	07150-07108	8.38	07150-09108	3.40	07150-07808

FASTENER	REF. N°	HOLE SIZE	2ND OVERSIZE MANDREL - BLUE					HOLE SIZE	3RD OVERSIZE MANDREL - RED					SPRING PART N°
			HEAD Ø	MANDREL PART N°	P MAX.	# S/R MANDREL PART N°	P MAX.		HEAD Ø	MANDREL PART N°	P MAX.	# S/R MANDREL PART N°	P MAX.	
3/32" CHOBERT® & GROVIT®	1	+09	1.93	07150-06103	4.70	-	-	-	-	-	-	-	-	07150-06803
	1	-	-	-	-	-	-	-	-	-	-	-	-	-
	2	+09	1.93	07150-06103	4.70	-	-	-	-	-	-	-	-	07170-06873
	2	-	-	-	-	-	-	-	-	-	-	-	-	-
	3	+09	1.93	07150-06103	4.70	-	-	-	-	-	-	-	-	07170-06903
	3	-	-	-	-	-	-	-	-	-	-	-	-	-
1/8" CHOBERT® & GROVIT®	4	+09	1.93	07150-07103	4.70	-	-	-	-	-	-	-	-	07150-07803
	4	-	-	-	-	-	-	-	-	-	-	-	-	-
1/8" CHOBERT® & GROVIT®	5	+25	2.49	07150-06204	6.81	07150-08204	2.79	+35	2.59	07150-06304	7.32	07150-08304	3.00	07150-06804
	6	+25	2.49	07150-07204	6.81	07150-09204	2.79	+35	2.59	07150-07304	7.32	07150-09304	3.00	07150-07804
5/32" CHOBERT® & GROVIT®	7	+38	3.10	07150-06205	8.13	07150-08205	3.30	-	-	-	-	-	-	07170-06875
	7	-	-	-	-	-	-	+63	3.35	07150-06305	9.45	07150-08305	3.81	07150-06805
	8	+38	3.10	07150-07205	8.13	07150-09205	3.30	-	-	-	-	-	-	07170-07875
	8	-	-	-	-	-	-	+63	3.35	07150-07305	9.45	07150-09305	3.81	07150-07805
3/16" CHOBERT® & GROVIT®	9	-	-	-	-	-	-	-	-	-	-	-	-	-
	9	+60	3.96	07150-06206	9.45	07150-08206	3.81	-	-	-	-	-	-	07150-06806
	10	+60	3.96	07150-07206	9.45	07150-09206	3.81	-	-	-	-	-	-	07150-07806
1/4" CHOBERT®	11	-	-	-	-	-	-	-	-	-	-	-	-	-
	12	-	-	-	-	-	-	-	-	-	-	-	-	-

S/R: Short Reach Mandrel. See page 19-20 for explanation.

Nose Assemblies

To find the correct part number of a mandrel for a particular application, read the instructions below after you have gathered the following information as per example alongside. Answers for the example are shown in *grey italic*.

FASTENER NAME	<i>example</i>	<i>Chobert®</i>
FASTENER SIZE		<i>1/8"</i>
DATASHEET		<i>Series 1125</i>
APPLICATION HOLE SIZE		<i>0.1335"</i>
CLEARANCE BEHIND APPLICATION		<i>Infinite</i>
'REF.N°' FROM NOSE JAW SELECTION TABLE		<i>5 (standard flat)</i>

- Subtract the minimum hole size recommended (AS REC.) in the fastener datasheet from the actual application hole size. *-example: 0.005.*
- Turn to the page with the 'Mandrel Selection' table for your fastener, selecting either the imperial or the metric dimensions table (pages 17-21). *-example: page 17.*
- Starting with the 'Standard Mandrel - Green' section, find your fastener size in the left-hand column. *-example 1/8" Chobert® & Grovit®.*
- If you selected a nose jaw which place you fastener, you should now be able to find a line within your fastener section with the same 'Ref No.' as that from the 'Nose Jaw Selection' table. *-example: 5.* This is your line 'Ref. No.' in which you will find both your mandrel and mandrel follower spring part number. This line continues into the second half of the table for the '2nd' and '3rd' oversize mandrels.
- Scan along the line to the 'hole size' columns and select which ever is the nearest or equal to the figure calculated in step one. You may now read the mandrel part number next to the 'hole size'. *-example: 07150-06104*
- For Chobert® and Grovit® only, most mandrels are also available in a 'short reach' version (see illustration on page 20). Short reach mandrels are used to minimise the possibility of the mandrel head contacting a read obstruction. This would result in the underside of the fastener head not seating properly on the application surface, causing a lack on clench in the joint.
- Whichever size mandrel you settle on, you will also need to check the 'P' figure against that mandrel is adequate. 'P' is the clearance required for the mandrel head at the back of the application IN ADDITION to the length of the fastener protruding through the application, as shown in the illustration on page 20.
- You may now read the corresponding mandrel follower spring part number in the right-hand column of the table. *-example: 07150-06804.*

In all cases, satisfactory clenching of the joint should be assessed particularly if the size of the hole in your application is very close to the next oversize hole condition, when it will be safe to select the greater size of mandrel to obtain a higher clench. REMEMBER that this will increase the broach load and reduce the mandrel life.

Briv® - Imperial

For mandrel or mandrel follower spring selection, follow instructions above.

FASTENER	REF. N°	HOLE SIZE	STANDARD MANDREL - GREEN			HOLE SIZE	1ST OVERSIZE MANDREL - YELLOW			SPRING PART N°
			HEAD Ø	MANDREL PART N°	P MAX.		HEAD Ø	MANDREL PART N°	P MAX.	
3/32" BRIV® Brass only	13	AS REC.	.072	07150-06013	.119	+.004	.076	07150-06113	.123	07170-06873
	14	AS REC.	.072	07150-06013	.119	+.004	.076	07150-06113	.123	07170-06903
1/8" BRIV® Al. Alloy, Brass, Steel	15	AS REC.	.092	07271-06414	.120	+.005	.097	07271-06514	.126	07150-06814
	16	AS REC.	.092	07271-07414	.120	+.005	.097	07271-07514	.126	07150-07814
5/32" BRIV® Al. Alloy, Brass, Steel	17	AS REC.	.110	07150-06015	.136	+.005	.115	07150-06115	.142	07170-06875
	18	AS REC.	.110	07150-07015	.136	+.005	.115	07150-07115	.142	07170-07875
5/32" BRIV® St.Steel only	19	AS REC.	.120	07170-06805	.126	+.005	.125	07170-06825	.132	07170-06875
	20	AS REC.	.120	07170-07805	.126	+.005	.125	07170-07825	.132	07170-07875
3/16" BRIV® Al. Alloy, Brass, Steel	21	AS REC.	.141	07150-06016	.157	+.005	.146	07150-06116	.164	07170-06876
	22	AS REC.	.141	07150-07016	.157	+.005	.146	07150-07116	.164	07170-07876
3/16" BRIV® St.Steel only	23	AS REC.	.153	07170-06806	.150	+.005	.158	07170-06826	.156	07170-06876
	24	AS REC.	.153	07170-07806	.150	+.005	.158	07170-07826	.156	07170-07876
6mm BRIV® Al. Alloy, Steel	25	AS REC.	.179	07150-06018	.165	+.005	.184	07150-06118	.171	07150-06846
	26	AS REC.	.179	07150-07018	.165	+.005	.184	07150-07118	.171	07150-07846

FASTENER	REF. N°	HOLE SIZE	2ND OVERSIZE MANDREL - BLUE			HOLE SIZE	3RD OVERSIZE MANDREL - RED			SPRING PART N°
			HEAD Ø	MANDREL PART N°	P MAX.		HEAD Ø	MANDREL PART N°	P MAX.	
3/32" BRIV® Brass only	13	+.008	.079	07150-06213	.126	-	-	-	-	07170-06873
	14	+.008	.079	07150-06213	.126	-	-	-	-	07170-06903
1/8" BRIV® Al. Alloy, Brass, Steel	15	+.010	.102	07271-06614	.133	-	-	-	-	07150-06814
	16	+.010	.102	07271-07614	.133	-	-	-	-	07150-07814
5/32" BRIV® Al. Alloy, Brass, Steel	17	+.010	.120	07150-06215	.149	-	-	-	-	07170-06875
	18	+.010	.120	07150-07215	.149	-	-	-	-	07170-07875
5/32" BRIV® St.Steel only	19	-	-	-	-	-	-	-	-	-
3/16" BRIV® Al. Alloy, Brass, Steel	21	+.010	.151	07150-06216	.170	+.012	.153	07150-06316	.173	07170-06876
	22	+.010	.151	07150-07216	.170	+.012	.153	07150-07316	.173	07170-07876
3/16" BRIV® St.Steel only	23	-	-	-	-	-	-	-	-	-
	24	-	-	-	-	-	-	-	-	-
6mm BRIV® Al. Alloy, Steel	25	+.010	.189	07150-06218	.177	-	-	-	-	07150-06846
	26	+.010	.189	07150-07218	.177	-	-	-	-	07150-07846

Nose Assemblies

Mandrel Head Types and 'P' Length

Mandrels for stainless steel Briv® are easily identifiable by a 'V' cut in the end of the mandrel heads.

When using curved nose jaws, mandrels have to be bent by hand to match the curvature of the nose jaw, thus ensuring good feed of fasteners.

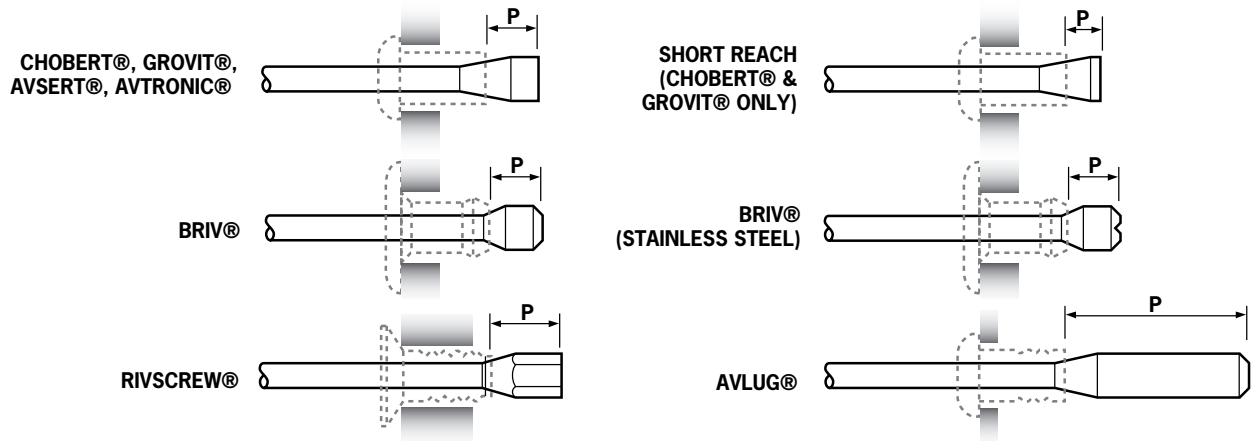

Briv® - Metric

FASTENER	REF. N°	HOLE SIZE	STANDARD MANDREL - GREEN			HOLE SIZE	1ST OVERSIZE MANDREL - YELLOW			SPRING PART N°
			HEAD Ø	MANDREL PART N°	P MAX.		HEAD Ø	MANDREL PART N°	P MAX.	
3/32" BRIV® Brass only	13	AS REC.	1.83	07150-06013	3.02	+10	1.93	07150-06113	3.12	07170-06873
	14	AS REC.	1.83	07150-06013	3.02	+10	1.93	07150-06113	3.12	07170-06903
1/8" BRIV® Al. Alloy, Brass, Steel	15	AS REC.	2.34	07271-06414	3.05	+13	2.46	07271-06514	3.20	07150-06814
	16	AS REC.	2.34	07271-07414	3.05	+13	2.46	07271-07514	3.20	07150-07814
5/32" BRIV® Al. Alloy, Brass, Steel	17	AS REC.	2.79	07150-06015	3.45	+13	2.92	07150-06115	3.61	07170-06875
	18	AS REC.	2.79	07150-07015	3.45	+13	2.92	07150-07115	3.61	07170-07875
5/32" BRIV® St. Steel only	19	AS REC.	3.05	07170-06805	3.20	+13	3.18	07170-06825	3.35	07170-06875
	20	AS REC.	3.05	07170-07805	3.20	+13	3.18	07170-07825	3.35	07170-07875
3/16" BRIV® Al. Alloy, Brass, Steel	21	AS REC.	3.58	07150-06016	3.99	+13	3.71	07150-06116	4.17	07170-06876
	22	AS REC.	3.58	07150-07016	3.99	+13	3.71	07150-07116	4.17	07170-07876
3/16" BRIV® St. Steel only	23	AS REC.	3.89	07170-06806	3.81	+13	4.01	07170-06826	3.96	07170-06876
	24	AS REC.	3.89	07170-07806	3.81	+13	4.01	07170-07826	3.96	07170-07876
6mm BRIV® Al. Alloy, Steel	25	AS REC	4.54	07150-06018	4.18	+13	4.67	07150-06118	4.34	07150-06846
	26	AS REC	4.54	07150-07018	4.18	+13	4.67	07150-07118	4.34	07150-07846

FASTENER	REF. N°	HOLE SIZE	2ND OVERSIZE MANDREL - BLUE			HOLE SIZE	3RD OVERSIZE MANDREL - RED			SPRING PART N°
			HEAD Ø	MANDREL PART N°	P MAX.		HEAD Ø	MANDREL PART N°	P MAX.	
3/32" BRIV® Brass only	13	+20	2.01	07150-06213	3.20	-	-	-	-	07170-06873
	14	+20	2.01	07150-06213	3.20	-	-	-	-	07170-06903
1/8" BRIV® Al. Alloy, Brass, Steel	15	+25	2.59	07271-06614	3.38	-	-	-	-	07150-06814
	16	+25	2.59	07271-07614	3.38	-	-	-	-	07150-07814
5/32" BRIV® Al. Alloy, Brass, Steel	17	+25	3.05	07150-06215	3.78	-	-	-	-	07170-06875
	18	+25	3.05	07150-07215	3.78	-	-	-	-	07170-07875
5/32" BRIV® St. Steel only	19	-	-	-	-	-	-	-	-	-
	20	-	-	-	-	-	-	-	-	-
3/16" BRIV® Al. Alloy, Brass, Steel	21	+25	3.84	07150-06216	4.32	+30	3.85	07150-06316	4.39	07170-06876
	22	+25	3.84	07150-07216	4.32	+30	3.85	07150-07316	4.39	07170-07876
3/16" BRIV® St. Steel only	23	-	-	-	-	-	-	-	-	-
	24	-	-	-	-	-	-	-	-	-
6mm BRIV® Al. Alloy, Steel	25	+25	4.79	07150-06218	4.49	-	-	-	-	07150-06846
	26	+25	4.79	07150-07218	4.49	-	-	-	-	07150-07846

Nose Assemblies

Avlug®, Avsert®, Avtronic® & Rivscrew® - Imperial & Metric

For mandrel or mandrel follower spring selection, follow instructions on page 19.

FASTENER	REF. N°	HOLE SIZE	STANDARD MANDREL - GREEN			HOLE SIZE	1ST OVERSIZE MANDREL - YELLOW			SPRING PART N°
			HEAD Ø	MANDREL PART N°	P MAX.		HEAD Ø	MANDREL PART N°	P MAX.	
3/32" AVLUG®	27	AS REC.	.076	07150-06603	.353	+0.05	.081	07150-06703	.478	07150-06803
	28	AS REC.	.076	07150-07603	.353	+0.03	.079	07150-07703	.368	07150-07803
1/8" AVLUG®	29	AS REC.	.098	07150-06604	.593	-	-	-	-	07150-06804
	30	AS REC.	.098	07150-07604	.593	-	-	-	-	07150-07804
2.5mm, 4-40 UNC AVSERT®	31	AS REC.	.0725	07150-06003	.145	-	-	-	-	07150-06803
3.0mm, 6-32 UNC AVSERT®	32	AS REC.	.088	07150-06004	.185	-	-	-	-	07150-06804
2.5mm AVTRONIC®	33	AS REC.	.070	07170-06025	.140	+0.03	.073	07170-06125	.140	07150-06803
	34	AS REC.	.070	07170-07025	.140	+0.03	.073	07170-07125	.140	07150-07803
2.8mm AVTRONIC®	35	AS REC.	.079	07170-06028	.150	+0.03	.082	07170-06128	.150	07170-06528
	36	AS REC.	.079	07170-06028	.150	+0.03	.082	07170-06128	.150	07170-06873
	37	AS REC.	.079	07170-07028	.150	+0.03	.082	07170-07128	.150	07170-07528
2.8mm RIVSCREW®	38	AS REC.	* .065	07271-06030	.127	-	-	-	-	07271-06630
3.0mm RIVSCREW®	39	AS REC.	* .065	07271-06030	.127	-	-	-	-	07271-06630
3.5mm RIVSCREW®	40	AS REC.	* .0825	07271-06035	.132	-	-	-	-	07271-06635
4.0mm RIVSCREW®	41	AS REC.	* .103	07271-06140	.150	-	-	-	-	07271-06640

* These Dimensions are Across Flats

FASTENER	REF. N°	HOLE SIZE	2ND OVERSIZE MANDREL - BLUE			HOLE SIZE	3RD OVERSIZE MANDREL - RED			SPRING PART N°
			HEAD Ø	MANDREL PART N°	P MAX.		HEAD Ø	MANDREL PART N°	P MAX.	
3/32" AVLUG®	27	-	-	-	-	-	-	-	-	-
	28	-	-	-	-	-	-	-	-	-
1/8" AVLUG®	29	-	-	-	-	-	-	-	-	-
	30	-	-	-	-	-	-	-	-	-
2.5mm, 4-40 UNC AVSERT®	31	-	-	-	-	-	-	-	-	-
3.0mm, 6-32 UNC AVSERT®	32	-	-	-	-	-	-	-	-	-
2.5mm AVTRONIC®	33	+0.06	.076	07170-06225	.140	-	-	-	-	07150-06803
	34	+0.06	.076	07170-07225	.140	-	-	-	-	07150-07803
2.8mm AVTRONIC®	35	+0.06	.085	07170-06228	.150	-	-	-	-	07170-06528
	36	+0.06	.085	07170-06228	.150	-	-	-	-	07170-06873
	37	+0.06	.085	07170-07228	.150	-	-	-	-	07170-07528
2.8mm RIVSCREW®	38	-	-	-	-	-	-	-	-	-
3.0mm RIVSCREW®	39	-	-	-	-	-	-	-	-	-
3.5mm RIVSCREW®	40	-	-	-	-	-	-	-	-	-
4.0mm RIVSCREW®	41	-	-	-	-	-	-	-	-	-

FASTENER	LINE N°	HOLE SIZE	STANDARD MANDREL - GREEN			HOLE SIZE	1ST OVERSIZE MANDREL - YELLOW			SPRING PART N°
			HEAD Ø	MANDREL PART N°	P MAX.		HEAD Ø	MANDREL PART N°	P MAX.	
3/32" AVLUG®	27	AS REC.	1.93	07150-06603	8.97	+10	2.06	07150-06703	12.14	07150-06803
	28	AS REC.	1.93	07150-07603	8.97	+10	2.01	07150-07703	9.35	07150-07803
1/8" AVLUG®	29	AS REC.	2.49	07150-06604	15.06	-	-	-	-	07150-06804
	30	AS REC.	2.49	07150-07604	15.06	-	-	-	-	07150-07804
2.5mm, 4-40 UNC AVSERT®	31	AS REC.	1.84	07150-06003	3.68	-	-	-	-	07150-06803
3.0mm, 6-32 UNC AVSERT®	32	AS REC.	2.24	07150-06004	4.70	-	-	-	-	07150-06804
2.5mm AVTRONIC®	33	AS REC.	1.78	07170-06025	3.56	+07	1.85	07170-06125	3.56	07150-06803
	34	AS REC.	1.78	07170-07025	3.56	+07	1.85	07170-07125	3.56	07150-07803
2.8mm AVTRONIC®	35	AS REC.	2.01	07170-06028	3.81	+07	2.08	07170-06128	3.81	07170-06528
	36	AS REC.	2.01	07170-06028	3.81	+07	2.08	07170-06128	3.81	07170-06873
	37	AS REC.	2.01	07170-07028	3.81	+07	2.08	07170-07128	3.81	07170-07528
2.8mm RIVSCREW®	38	AS REC.	* 1.65	07271-06030	3.23	-	-	-	-	07271-06630
3.0mm RIVSCREW®	39	AS REC.	* 1.65	07271-06030	3.23	-	-	-	-	07271-06630
3.5mm RIVSCREW®	40	AS REC.	* 2.10	07271-06035	3.35	-	-	-	-	07271-06635
4.0mm RIVSCREW®	41	AS REC.	* 2.62	07271-06140	3.81	-	-	-	-	07271-06640

* These Dimensions are Across Flats

FASTENER	LINE N°	HOLE SIZE	2ND OVERSIZE MANDREL - BLUE			HOLE SIZE	3RD OVERSIZE MANDREL - RED			SPRING PART N°
			HEAD Ø	MANDREL PART N°	P MAX.		HEAD Ø	MANDREL PART N°	P MAX.	
3/32" AVLUG®	27	-	-	-	-	-	-	-	-	-
	28	-	-	-	-	-	-	-	-	-
1/8" AVLUG®	29	-	-	-	-	-	-	-	-	-
	30	-	-	-	-	-	-	-	-	-
2.5mm, 4-40 UNC AVSERT®	31	-	-	-	-	-	-	-	-	-
3.0mm, 6-32 UNC AVSERT®	32	-	-	-	-	-	-	-	-	-
2.5mm AVTRONIC®	33	+15	1.93	07170-06225	3.56	-	-	-	-	07150-06803
	34	+15	1.93	07170-07225	3.56	-	-	-	-	07150-07803
2.8mm AVTRONIC®	35	+15	2.16	07170-06228	3.81	-	-	-	-	07170-06528
	36	+15	2.16	07170-06228	3.81	-	-	-	-	07170-06873
	37	+15	2.16	07170-07228	3.81	-	-	-	-	07170-07528
2.8mm RIVSCREW®	38	-	-	-	-	-	-	-	-	-
3.0mm RIVSCREW®	39	-	-	-	-	-	-	-	-	-
3.5mm RIVSCREW®	40	-	-	-	-	-	-	-	-	-
4.0mm RIVSCREW®	41	-	-	-	-	-	-	-	-	-

Servicing the Tool

Regular servicing should be carried out and a comprehensive inspection performed annually or every 500,000 cycles, whichever is sooner.

I M P O R T A N T

**The employer is responsible for ensuring that tool maintenance instructions are given to the appropriate personnel.
The operator should not be involved in maintenance or repair of the tool unless properly trained.**

Daily

- Daily, before use or when first putting the tool into service. Pour a few drops of clean lubricating oil into the air inlet of the intensifier if no lubricator is fitted on air supply. If the tool is in continuous use, the air hose should be disconnected from the main air supply and the tool lubricated every two to three hours.
- Check for air and oil leaks. If damaged, hoses and couplings should be replaced.
- If there is no filter on the pressure regulator, bleed the airline to clear it of accumulated dirt or water before connecting the air hose to the intensifier. If there is a filter, drain it.
- Check that the nose equipment is correct.
- Check mandrels regularly for signs of wear or damage monitoring the number of placings (read the safety instructions on page 4).

Weekly

- Conduct the full "Daily" procedures as described above.
- Remove, inspect, clean and grease the Tail Jaws (refer to "Tail Jaw Cylinder" in the "Maintenance Section" page 24).
- Check oil level in the intensifier Unit reservoir is approximately 12mm (1/2") below the transparent cover plate.

Moly Lithium Grease EP 3753 Safety Data

Grease can be ordered as a single item, the part number is shown in the service kit page 23.

First Aid

SKIN:

As the grease is completely water resistant it is best removed with an approved emulsifying skin cleaner.

INGESTION:

Ensure the individual drinks 30ml Milk of Magnesia, preferably in a cup of milk.

EYES:

Irritant but not harmful. Irrigate with water and seek medical attention.

Fire

FLASH POINT: Above 220°C.

Not classified as flammable.

Suitable extinguishing media: CO₂, Halon or water spray if applied by an experienced operator.

Environment

Scrape up for burning or disposal on approved site.

Handling

Use barrier cream or oil resistant gloves

Storage

Away from heat and oxidising agent.

Servicing the Tool

Service Kit

For all servicing we recommend the use of the service kit (part number 07900-05300).

SERVICE KIT					
ITEM PART N°	DESCRIPTION	N° OFF	ITEM PART N°	DESCRIPTION	N° OFF
07900-00157	CIRCLIP PLIERS	1	07900-00352	SEAL REMOVAL HOOK	1
07900-00006	SPATULA	1	07900-00710	BARREL PLUG REMOVAL SPANNER	1
07900-00446	EXTRACTOR	1	07900-00725	BULLET	1
07900-00603	BARREL VICE JAWS	1	07900-00243	SCREWDRIVER	1
07900-00520	3/8" ROD	1	07900-00717	INTENSIFIER SPANNER	1
07900-00521	1/4" ROD	1	07900-00013	1/8" ALLEN KEY	1
07900-00602	'O' RING ASSEMBLY BULLET	1	07900-00617	LOCTITE MULTI-GASKET 574 50ml PACK	1
07900-00595	18mm SPANNER	1	07900-00469	2.5mm ALLEN KEY	1
07900-00434	32mm SPANNER	1	07900-00351	3mm ALLEN KEY	1
07900-00237	3/8" x 5/16" B.S.W. SPANNER	1	07900-00224	4mm ALLEN KEY	1
07900-00012	9/16" x 5/8" SPANNER	1	07900-00225	5mm ALLEN KEY	1
07900-00008	7/16" x 1/2" SPANNER	1	07992-00020	80g TIN MOLY LITHIUM GREASE EP 3753	1

Note: Spanner sizes are measured 'across flats' unless otherwise specified.

Maintenance

Every 500,000 cycles the tool should be completely dismantled and new components should be used where worn, damaged or when recommended. All 'O' rings and seals should be renewed and lubricated with Moly Lithium grease EP 3753 before assembling.

IMPORTANT

Safety Instructions appear on page 4.
The employer is responsible for ensuring that tool maintenance instructions are given to the appropriate personnel.
The operator should not be involved in maintenance or repair of the tool unless properly trained.

The airline must be disconnected before any servicing or dismantling is attempted, unless specifically instructed otherwise.

It is recommended that any dismantling operation be carried out in clean conditions.

Dismantling of the 07530 Mkl and 07532 Mkl are covered separately. For the 07530 Mkl refer to the dismantling procedures below and for the 07532 Mkl refer to pages 26-27. Item numbers in **bold** refer to the general assemblies and parts lists for the respective model on pages 28-31.

Prior to dismantling the tool, you will need to remove the nose equipment.

For total tool servicing we advise that you proceed with the dismantling of sub-assemblies in the order shown below after having disconnected the hydraulic hose from the intensifier unit and the trigger air line from the intensifier valve, thus separating the pistol unit from the intensifier unit.

Dismantling 07530-02200 Mkl

To dismantle the 07532-02200 Mkl refer to pages 26-27.

TAIL JAW CYLINDER

- Manually flip the Clip **47** up and remove the End Cap **38**.
- Using an Allen Key*, remove one Cap Head Screw **44** ensuring that any trapped air in the tail jaw cylinder is exhausted. Remove the second Cap Head Screw **44**.
- Pull out Rear Plug **46**.
- Extract air tail jaw components, comprising Tail Jaw Piston Assembly **14**, Spring **13**, Jaws **9** and Jaw Housing **8**.
- Remove plug at rear of piston assembly using an Allen Key* and a bar through the large slot in the turret.
- Clean out turret using a 4.7mm ($\frac{3}{16}$ ") drill and replace plug using a non-hardening sealing compound, e.g. Loctite Multi-gasket 574*.
- Remove piston seal 'O' Ring **10**.
- Using an Allen Key*, remove all five handle moulding securing Screws **34**, **39** and Nuts **33** from the tool handle.
- Grip Barrel **25** in a vice using soft jaws* to avoid damage.
- Using a box spanner*, unscrew Barrel Plug **7**, preventing Barrel **25** turning by using an open ended spanner*.
- Disconnect Air Tail Jaw Concertina Tube **12** from Switch Block **28** and pull Tail Jaw Cylinder **6** from tool.
- Remove 'O' Ring **4**, Rubbing Strip **15** and Barrel Return Spring **16**.

- Free length of Spring **13** should be 38.1mm (1.5"). Replace if necessary.
- Coat the tail jaws with Moly Lithium grease before assembling.

- Assemble in reverse order of dismantling.

HYDRAULIC PISTON

- Remove Tail Jaw Cylinder **6** as described earlier.
- Grip Body **19** in vice using soft jaws* to avoid damage, undo Stroke Limiter **17**.
- Grip Barrel **25** in soft jaw vice, pull Body **19** from Barrel **25** (a small quantity of hydraulic oil will be ejected from inside body).
- Remove Piston **18** carefully so as not to damage body bore.
- Remove Seal **3**.
- Seal **1** is difficult to remove without damaging, but can remain in place during cleaning (provided it is not affected by cleaning process). If however, Seal **1** requires renewing proceed as follows:
- Using spatula*, prise out Seal **1** from Body **19**, taking care not to damage body cavity and bores. The removed Seal **1** MUST be discarded.

- To replace Seal **1**, unscrew Hydraulic Hose Assembly **22** and fit a spare Bleed Plug Assembly **2** screwing it in to bring inside face level with internal bore.
- Unscrew existing bleed plug until inside face is level with internal bore. This will provide a smooth passage for insertion of new Seal **1** through rear of body.
- Ensure the seal is well greased and the correct way round with the open end of the seal facing the rear tail jaws.
- Complete assembly in reverse order of dismantling.

* Refers to items included in the 0753 Mkl service kit. For complete list see page 23. Item numbers in **bold** refer to the general assemblies and parts lists on pages 28-29.

Maintenance

Dismantling 07530-02200 MkII

TRIGGER ASSEMBLY

- To dismantle/service assembly, remove covers from the tool as described earlier.
- Disconnect all air hoses from assembly, taking care not to damage them. Remove assembly.
- Using a spanner*, unscrew the Retainer **49** and remove. Take care to keep the Spring **50**.
- Prise off the 'O' Ring **53** taking care not to damage the Spindle **54** and Retainer **49** seatings.
- Clean and re-assemble using a new 'O' Ring **53**.
- Check length of Spring **50** which must be 12.7mm (0.5") free length – replace if necessary.
- Assembly in reverse order of dismantling.

TAIL JAW ON/OFF VALVE

- The unit is designed so that minimum of servicing is required during the life of the tool.
- If it is necessary to dismantle valve, proceed as follows:
- Disconnect air hose from assembly, taking care not to damage them. Remove assembly.
- Using an Allen Key*, loosen Screw **27** clamping assembly to Barrel **25** and remove assembly.
- Using a screwdriver*, carefully remove the Chrome Star-lock Washer **26** from Air Tail Jaw Spool **29** and discard washer.
- Extract Air Tail Jaw Spool **29** from Switch Block **28**.
- Taking care not to damage the Air Tail Jaw Spool **29**, remove the 'O' Rings **31**.
- Clean spool and refit new 'O' Rings **31** using assembly bullet* and insert into Switch Block **28**, noting its orientation.
- Fit New Chrome Star-lock Washer **26** by clamping in vice using a soft jaw vice to prevent damage. DO NOT USE UNDUE FORCE.
- Complete assembly in reverse order of dismantling.

TAIL JAW PRESSURE NON-RETURN VALVE

- The Non-return Valve **21** is located in the tool handle.
- To remove/replace the Non-return Valve **21** depress the bulk head fittings and withdraw the Blue Plastic Tube **23** from both ends.
- When replacing the Non-return Valve **21**, note the orientation.

HANDLE & END CAP

- Clean and inspect mouldings for cracks or other damage.

CURSOR

- Clean and oil Mechanical Cursor Assembly **5** occasionally with a little light oil.

IMPORTANT

**Check the tool against daily and weekly servicing.
Priming is ALWAYS necessary after the tool has been dismantled and prior to operating.**

* Refers to items included in the 0753 MkII service kit. For complete list see page 23.
Item numbers in **bold** refer to the general assemblies and parts lists on pages 28-29.

Maintenance

Dismantling 07532-02200 MkII

To dismantle the 07530-02200 MkII refer to pages 24-25.

TAIL JAW CYLINDER

- Manually flip the Clip **54** up and remove the End Cap **45**.
 - Using an Allen Key*, remove one cap head Screw **51** ensuring that any trapped air in the tail jaw cylinder is exhausted. Remove the second cap head Screw **51**.
 - Push forward Rear Plug **53** against Spring **20** and release quickly to allow Rear Plug **53** to fall away.
 - Extract air tail jaw components, comprising Tail Jaw Piston Assembly **21**, Spring **20**, Jaws **16** and Jaw Housing **15**.
 - Remove plug at rear of piston assembly using an Allen Key* and a bar through the large slot in the turret.
 - Clean out turret using a 4.7mm ($\frac{3}{16}$ ") drill and replace plug using a non-hardening sealing compound, e.g. Loctite Multi-gasket 574*.
 - Remove piston seal 'O' Ring **17**.
 - Using an Allen Key*, remove all five handle moulding securing Screws **41**, **46** and Nuts **40** from the tool handle.
 - Grip Barrel **31** in a vice using soft jaws* to avoid damage.
 - Using a box spanner*, unscrew Barrel Plug **14**, preventing Barrel **31** turning by using an open ended spanner*.
 - Disconnect Air Tail Jaw Concertina Tube **19** from Switch Block **35** and pull Tail Jaw Cylinder **12** from tool.
 - Remove 'O' Ring **10**, Rubbing Strip **22** and Barrel Return Spring **13**.
-
- Free length of Spring **20** should be 38.1mm (1.5"). Replace if necessary.
 - Coat the tail jaws with Moly Lithium grease before assembling.
-
- Assemble in reverse order of dismantling.

HYDRAULIC PISTON

- Remove Tail Jaw Cylinder **12** as described earlier.
 - Grip Body **25** in vice using soft jaws* to avoid damage, undo Stroke Limiter **23**.
 - Grip Barrel **31** in soft jaw vice, pull Body **25** from Barrel **31** (a small quantity of hydraulic oil will be ejected from inside body).
 - Remove Piston **24** carefully so as not to damage body bore.
 - Remove Seal **9**.
 - Seal **1** is difficult to remove without damaging, but can remain in place during cleaning (provided it is not affected by cleaning process). If however, Seal **1** requires renewing proceed as follows:
 - Using spatula*, prise out Seal **1** from Body **25**, taking care not to damage body cavity and bores. The removed Seal **1** MUST be discarded.
-
- To replace Seal **1**, disconnect Hydraulic Hose Assembly **63** and all the associated air pipes. Unscrew Self Closing Coupler **6**, remove Suspension Mounting Plate **4**, unscrew the Adapter Top Hose **2** and fit a spare Bleed Plug Assembly **30** screwing it into bring the inside face level with the internal bore.
 - Unscrew existing bleed plug until inside face is level with internal bore. This will provide a smooth passage for insertion of new Seal **1** through rear of body.
 - Ensure the seal is well greased and the correct way round with the open end of the seal facing the rear tail jaws.
 - Complete assembly in reverse order of dismantling.

* Refers to items included in the 0753 MkII service kit. For complete list see page 23.
Item numbers in **bold** refer to the general assemblies and parts lists on pages 30-31.

Maintenance

Dismantling 07532-02200 MkII

TRIGGER ASSEMBLY

- To dismantle/service assembly, remove covers from the tool as described earlier.
- Disconnect all air hoses from assembly, taking care not to damage them. Remove assembly.
- Using a spanner*, unscrew the Retainer **56** and remove. Take care to keep the Spring **57**.
- Prise off the 'O' Ring **60** taking care not to damage the Spindle **61** and Retainer **56** seatings.
- Clean and re-assemble using a new 'O' Ring **60**.
- Check length of Spring **57** which must be 12.7mm (0.5") free length – replace if necessary.
- Assembly in reverse order of dismantling.

TAIL JAW ON/OFF VALVE

- The unit is designed so that minimum of servicing is required during the life of the tool.
- If it is necessary to dismantle valve, proceed as follows:
- Disconnect air hose from assembly, taking care not to damage them. Remove assembly.
- Using an Allen Key*, loosen Screw **34** clamping assembly to Barrel **31** and remove assembly.
- Using a screwdriver*, carefully remove the Chrome Star-lock Washer **33** from Air Tail Jaw Spool **36** and discard washer.
- Extract Air Tail Jaw Spool **36** from Switch Block **35**.
- Taking care not to damage the Air Tail Jaw Spool **36**, remove the 'O' Rings **38**.
- Clean spool and refit new 'O' Rings **38** using assembly bullet* and insert into Switch Block **35**, noting its orientation.
- Fit New Chrome Star-lock Washer **33** by clamping in vice using soft Jaws to prevent damage. DO NOT USE UNDUE FORCE.
- Complete assembly in reverse order of dismantling.

TAIL JAW PRESSURE NON-RETURN VALVE

- The Non-return Valve **26** is located in the tool handle.
- To remove/replace the Non-return Valve **26** depress the bulk head fittings and withdraw Blue Plastic Tube **27** from both ends.
- When replacing the Non-return Valve **26**, note the orientation.

HANDLE & END CAP

- Clean and inspect mouldings for cracks or other damage.

CURSOR

- Clean and oil Mechanical Cursor Assembly **11** occasionally with a little light oil.

IMPORTANT

**Check the tool against daily and weekly servicing.
Priming is ALWAYS necessary after the tool has been dismantled and prior to operating.**

* Refers to items included in the 0753 MkII service kit. For complete list see page 23.
Item numbers in **bold** refer to the general assemblies and parts lists on pages 30-31.

General Assembly of Base Tool 07530-02200 MkII

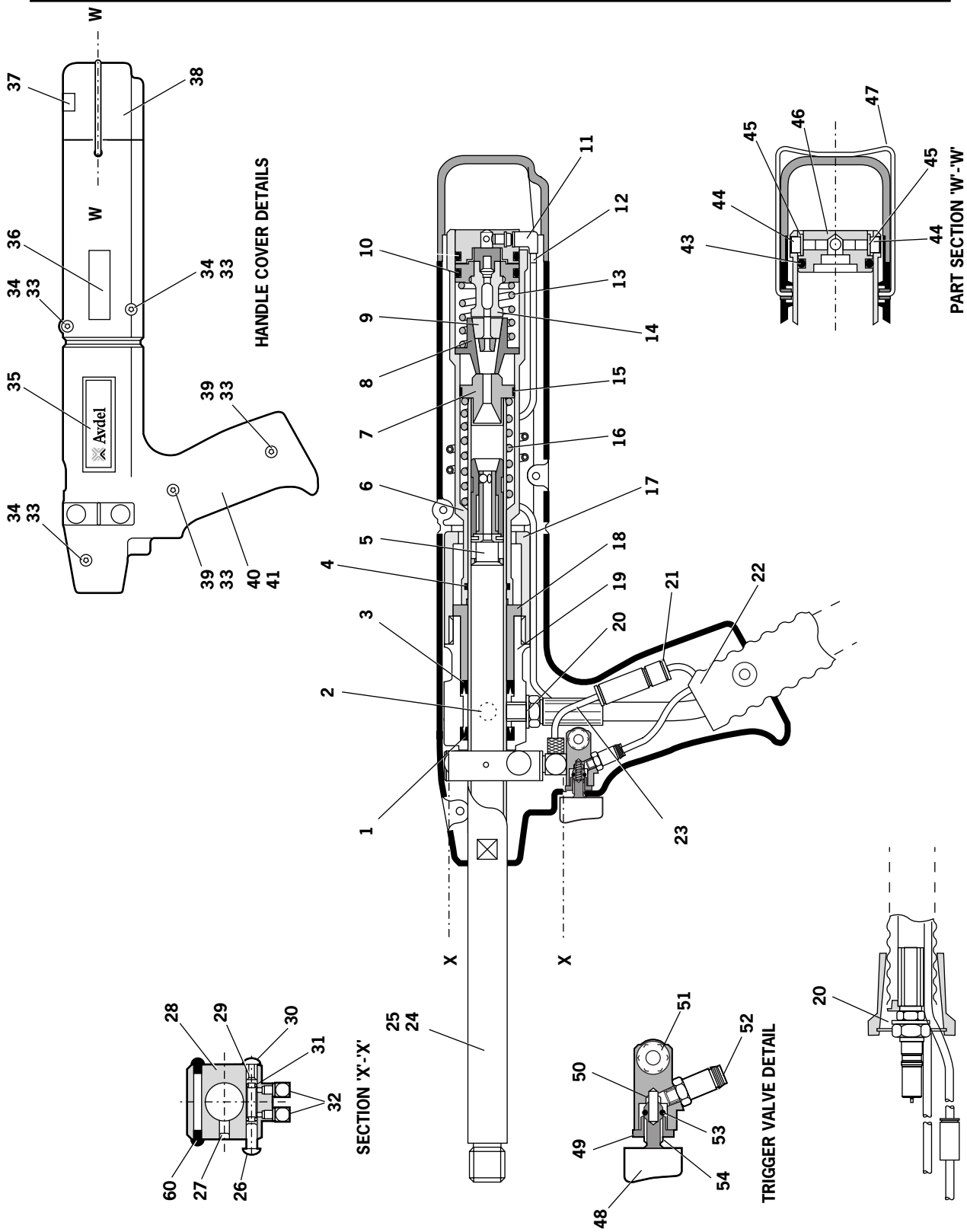

Parts List for Base Tool 07530-02200 MkII

07530-02200 PARTS LIST									
ITEM	PART N°	DESCRIPTION	QTY	SPARES	ITEM	PART N°	DESCRIPTION	QTY	SPARES
1	07003-00237	SEAL (STATIC)	1	-	29	07530-02302	AIR TAIL JAW SPOOL	1	-
2	07530-00500	BLEED PLUG ASSEMBLY (ITEMS 56 to 59)	1	-	30	07004-00059	1/8" STARLOCK WASHER BLACK	1	-
3	07003-00236	SEAL (DYNAMIC)	1	1	31	07003-00121	'O' RING	2	3
4	07003-00167	'O' RING	1	1	32	07005-01571	ELBOW CONNECTOR	2	-
5	07271-01100	MECHANICAL CURSOR ASSEMBLY	1	-	33	07002-00134	M4 HEX NUT	5	-
6	07530-02207	TAIL JAW CYLINDER	1	-	34	07001-00401	M4 X 10 LONG SOCKET HEAD CAP SCREW	3	-
7	07530-02205	BARREL PLUG	1	-	35	07530-02210	LABEL	2	-
8	07530-00208	JAW HOUSING	1	-	36	07007-01504	CE MARK LABEL	1	-
9	07151-00403	JAWS	2	2	37	07007-01503	BOOK SYMBOL LABEL	1	-
10	07003-00113	'O' RING	1	2	38	07530-02603	END CAP	1	-
11	07005-01972	L TYPE THREADED NIPPLE	1	-	39	07001-00262	M4 X 22 LONG SOCKET HEAD CAP SCREW	2	-
12	07530-02211	AIR TAIL JAW CONCERTINA TUBE	1	-	40	07530-02601	MODIFIED HANDLE MOULDING (RIGHT)	1	-
13	07154-00404	SPRING	1	-	41	07530-02602	MODIFIED HANDLE MOULDING (LEFT)	1	-
14	07530-02800	TAIL JAW PISTON ASSEMBLY	1	-	43	07003-00113	'O' RING	1	-
15	07530-00206	RUBBING STRIP	1	1	44	07001-00504	M4 X 6 LONG SOCKET HEAD CAP SCREW	2	2
16	07490-03002	BARREL RETURN SPRING	1	-	45	07002-00153	M4 WASHER PLASTIC	2	-
17	07530-00204	STROKE LIMITER	1	-	46	07530-02213	REAR PLUG	1	-
18	07530-00203	PISTON	1	-	47	07530-02220	CLIP	1	-
19	07530-02202	BODY	1	-	48	07007-00300	TRIGGER BUTTON	1	-
20	07003-00142	1/8" BSP BONDED SEAL	2	2	49	07220-00803	RETAINER	1	-
21	07005-01973	NON-RETURN VALVE	1	-	50	07125-00215	SPRING	1	-
22	07008-00423	HYDRAULIC HOSE ASSEMBLY	1	-	51	07530-02311	TRIGGER HOUSING	1	-
23	07005-01083	4mm O/D BLUE PLASTIC TUBE	60mm	-	52	07005-01357	COLLET TYPE CONNECTOR	1	-
24	07007-00017	DUST CAP	1	-	53	07003-00022	'O' RING	1	-
25	07530-02201	BARREL	1	-	54	07241-00208	SPINDLE	1	-
26	07004-00058	1/8" STARLOCK WASHER CHROME	1	-	56	07003-00142	● BONDED SEAL	1	1
27	07001-00404	M5 X 6 LONG SOCKET HEAD SCREW	1	-	57	07003-00194	● BONDED SEAL	1	1
28	07530-02301	SWITCH BLOCK	1	-	58	07001-00442	● SCREW	1	-
					59	07530-00501	● PLUG	1	-
					60	07530-00310	BLANKING PLUGS	2	-

General Assembly of Base Tool 07532-02200 MkII

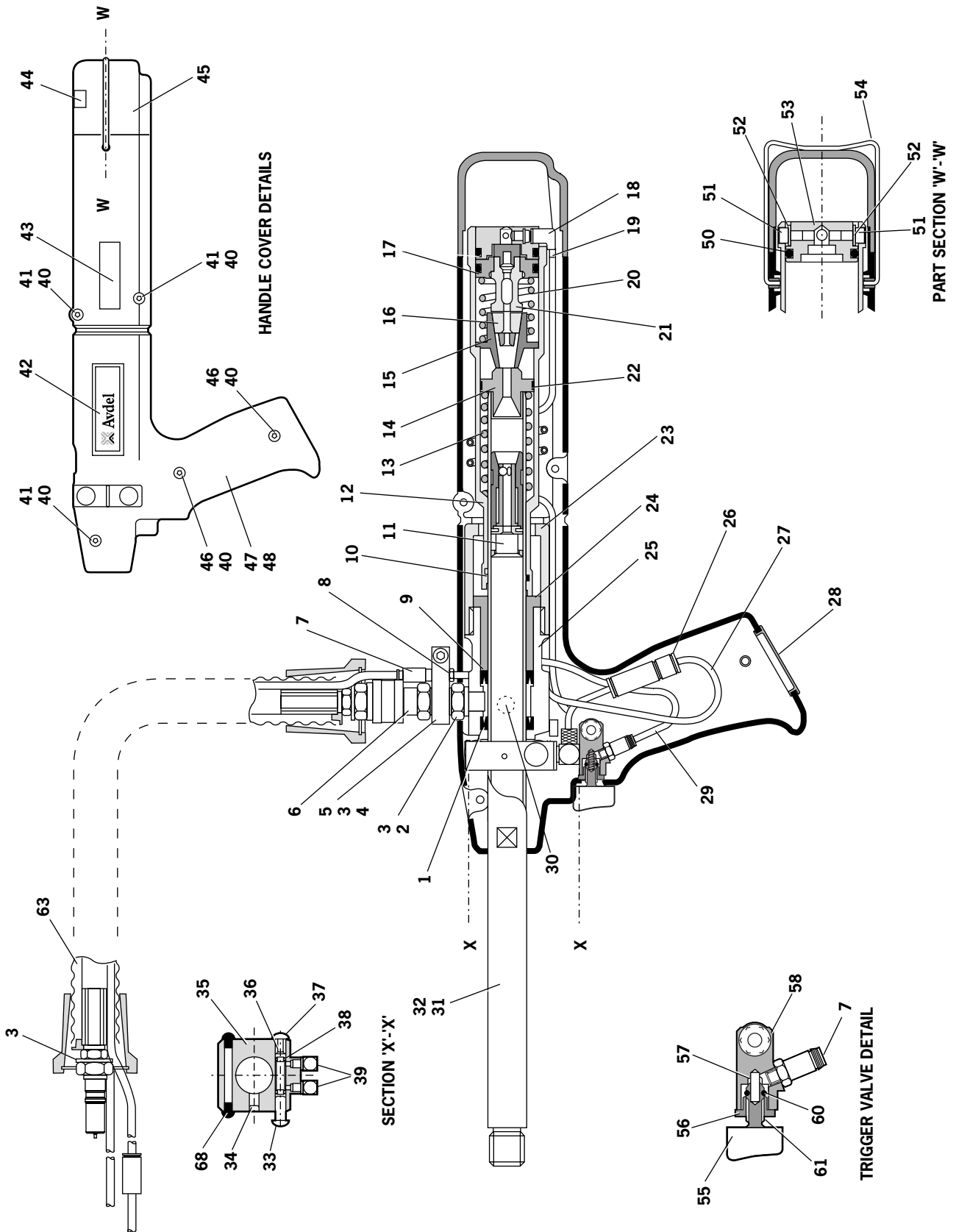

Parts List for Base Tool 07532-02200 MkII

07532-02200 PARTS LIST									
ITEM	PART N°	DESCRIPTION	QTY	SPARES	ITEM	PART N°	DESCRIPTION	QTY	SPARES
1	07003-00237	SEAL (STATIC)	1	-	33	07004-00058	1/8" STARLOCK WASHER CHROME	1	-
2	07532-00203	ADAPTOR TOP HOSE	1	-	34	07001-00404	M5 X 6 LONG SOCKET HEAD SCREW	1	-
3	07003-00142	1/8" BSP BONDED SEAL	4	2	35	07530-02301	SWITCH BLOCK	1	-
4	07532-02202	SUSPENSION MOUNTING PLATE	1	-	36	07530-02302	AIR TAIL JAW SPOOL	1	-
5	07532-00205	MODIFIED SCREW	1	-	37	07004-00059	1/8" STARLOCK WASHER BLACK	1	-
6	07005-00759	SELF CLOSING COUPLER	1	-	38	07003-00121	'O' RING	2	3
7	07005-01357	COLLET TYPE CONNECTOR	3	-	39	07005-01571	ELBOW CONNECTOR	2	-
8	07005-01325	BARBED STRAIGHT CONNECTOR	2	-	40	07002-00134	M4 HEX NUT	5	-
9	07003-00236	SEAL (DYNAMIC)	1	1	41	07001-00401	M4 X 10 LONG SOCKET HEAD CAP SCREW	3	-
10	07003-00167	'O' RING	1	1	42	07530-02210	LABEL	2	-
11	07271-01100	MECHANICAL CURSOR ASSEMBLY	1	-	43	07007-01504	CE MARK LABEL	1	-
12	07530-02207	TAIL JAW CYLINDER	1	-	44	07007-01503	BOOK SYMBOL LABEL	1	-
13	07490-03002	BARREL RETURN SPRING	1	-	45	07530-02603	END CAP	1	-
14	07530-02205	BARREL PLUG	1	-	46	07001-00262	M4 X 22 LONG SOCKET HEAD CAP SCREW	2	-
15	07530-00208	JAW HOUSING	1	-	47	07532-02208	MODIFIED HANDLE MOULDING (RIGHT)	1	-
16	07151-00403	JAWS	2	2	48	07532-02209	MODIFIED HANDLE MOULDING (LEFT)	1	-
17	07003-00113	'O' RING	1	2	50	07003-00113	'O' RING	1	-
18	07005-01972	L TYPE THREADED NIPPLE	1	-	51	07001-00504	M4 X 6 LONG SOCKET HEAD CAP SCREW	2	2
19	07530-02211	AIR TAIL JAW CONCERTINA TUBE	1	-	52	07002-00153	M4 WASHER PLASTIC	2	-
20	07154-00404	SPRING	1	-	53	07530-02213	REAR PLUG	1	-
21	07530-02800	TAIL JAW PISTON ASSEMBLY	1	-	54	07530-02220	CLIP	1	-
22	07530-00206	RUBBING STRIP	1	1	55	07007-00300	TRIGGER BUTTON	1	-
23	07530-00204	STROKE LIMITER	1	-	56	07220-00803	RETAINER	1	-
24	07530-00203	PISTON	1	-	57	07125-00215	SPRING	1	-
25	07530-02202	BODY	1	-	58	07530-02311	TRIGGER HOUSING	1	-
26	07005-01973	NON-RETURN VALVE	1	-	60	07003-00022	'O' RING	1	-
27	07005-01083	4mm O/D BLUE PLASTIC TUBE	350mm	-	61	07241-00208	SPINDLE	1	-
28	07532-02215	SEALING PLUG	1	-	63	07008-00414	HYDRAULIC HOSE ASSEMBLY	1	-
29	07005-01084	4mm O/D BLACK PLASTIC TUBE	220mm	-	64	07003-00142	● BONDED SEAL	1	1
30	07530-00500	BLEED PLUG ASSEMBLY (ITEMS 64 to 67)	1	-	65	07003-00194	● BONDED SEAL	1	1
31	07530-02201	BARREL	1	-	66	07001-00442	● SCREW	1	-
32	07007-00017	DUST CAP	1	-	67	07530-00501	● PLUG	1	-
					68	07530-00310	BLANKING PLATE	2	-

Intensifier 07531-02200 - Maintenance

Dismantling Instructions

- When dismantling the intensifier assembly, first disconnect the air supply hose to intensifier inlet Connector **22**.
- Using an Allen Key* undo four Screws **27** and remove Protection Plate **24**.
- Disconnect the trigger hose (item 22 on page 28 or item 29 on page 30) from the intensifier Valve **43** or **48** by depressing the outlet collet and withdrawing the hose.
- Remove Cover Plate **4** and Gasket **35** by removing Screws **37** and Washers **36** using Allen Key*.
- Ensure that gasket is not damaged to ensure a proper seal on assembly.
- Invert intensifier assembly and drain oil from reservoir into a suitable container.
- Remove Quick Release Connector **32** together with Connector **31** and Seals **33** with suitable spanner*.
- Remove intensifier Valve **43** or **48** by removing the fixing screws with a suitable spanner taking care to retain 'O' Ring **21** located in the Intensifier Body Casting.
- Remove Screw **19** using a suitable Allen Key* and remove Silencer Cover **16**, Foam Silencer **15**, Spacer **18** and Retaining Plate **20**.
- Pull off the 6mm Plastic Tube **41** from Vacuum Connectors **42**.
- From the base of the intensifier insert a 3mm Allen Key * through the two holes and unscrew the Vacuum Connectors **42**. Note:
 - Care must be taken as the vacuum connectors are locked and sealed in place using Loctite 574.
 - If difficult to remove, the vacuum connectors can be drilled out using a $\frac{3}{16}$ " or 4.7mm diameter drill.
- To reassemble the Vacuum Connectors **42**, the following procedure must be followed: -
 - Soak the vacuum connectors in a suitable primer, i.e. Perma Bond A905
 - Place a drop of Loctite 574 in the intensifier threaded hole.
 - From the base of the intensifier insert the Allen Key * through the hole. Ensure that the Allen Key * is free from Loctite 574 before inserting into the vacuum connector.
 - Rotate the Allen Key while applying Loctite 574 to the base of the vacuum connector.
 - Screw the Vacuum connector into the intensifier, ensuring that there is sufficient Loctite 574 at the base of the fitting such the thread is not visible.
- Using a screwdriver, carefully remove internal Retaining Ring **14**. Clean and inspect groove for sign of damage.
- Using Extractor*, insert male threaded end into End Cover **12** and withdraw it along with intensifier Sleeve **28** and 'O' Rings **10** and **13**.
- Insert Rod* through the connector orifice at the front of the intensifier body and tap out Piston Rod **9** and Piston Assembly.
- Using a suitable Allen Key*, unscrew two Screws **25** and remove End Cover **12** from intensifier Sleeve **28**.
- Remove Seal Plug **7** with spanner*.
- Insert rod* through connector orifice at the front of the intensifier body and push out Seal Housing **5** and associated 'O' rings and lip seals.
- Remove Valve Housing Assembly **34** from the main body with a suitable spanner*. Clean by blowing through with a low-pressure air jet.
- Remove Piston Rod **9** from intensifier Air Piston **11** by gripping the first 20 mm ($\frac{3}{4}$ ") of the rod in a vice fitted with soft jaws, taking care not to damage or mark the working surface.
- Unscrew locking Nut **17** with a suitable spanner*.
- Assemble in the reverse order of dismantling, observing the following:
 - Clean all parts and renew all 'O' rings.
 - Lubricate all seals using Moly Lithium grease.
 - Valve Housing Assembly **34** must be refitted using a thread sealing adhesive.
 - Assemble the Piston Assembly using a new Nut **17**.
- End Cover **12** must be fitted correctly inside Retaining Ring **14**. The tool must not be operated if the end cover has been omitted.

I M P O R T A N T

Priming is ALWAYS necessary after the tool has been dismantled and prior to operating.

* Refers to items included in the 0753 MkII service kit. For complete list see page 23.
Item numbers in **bold** refer to the illustration and parts list opposite.

Intensifier 07531-02200

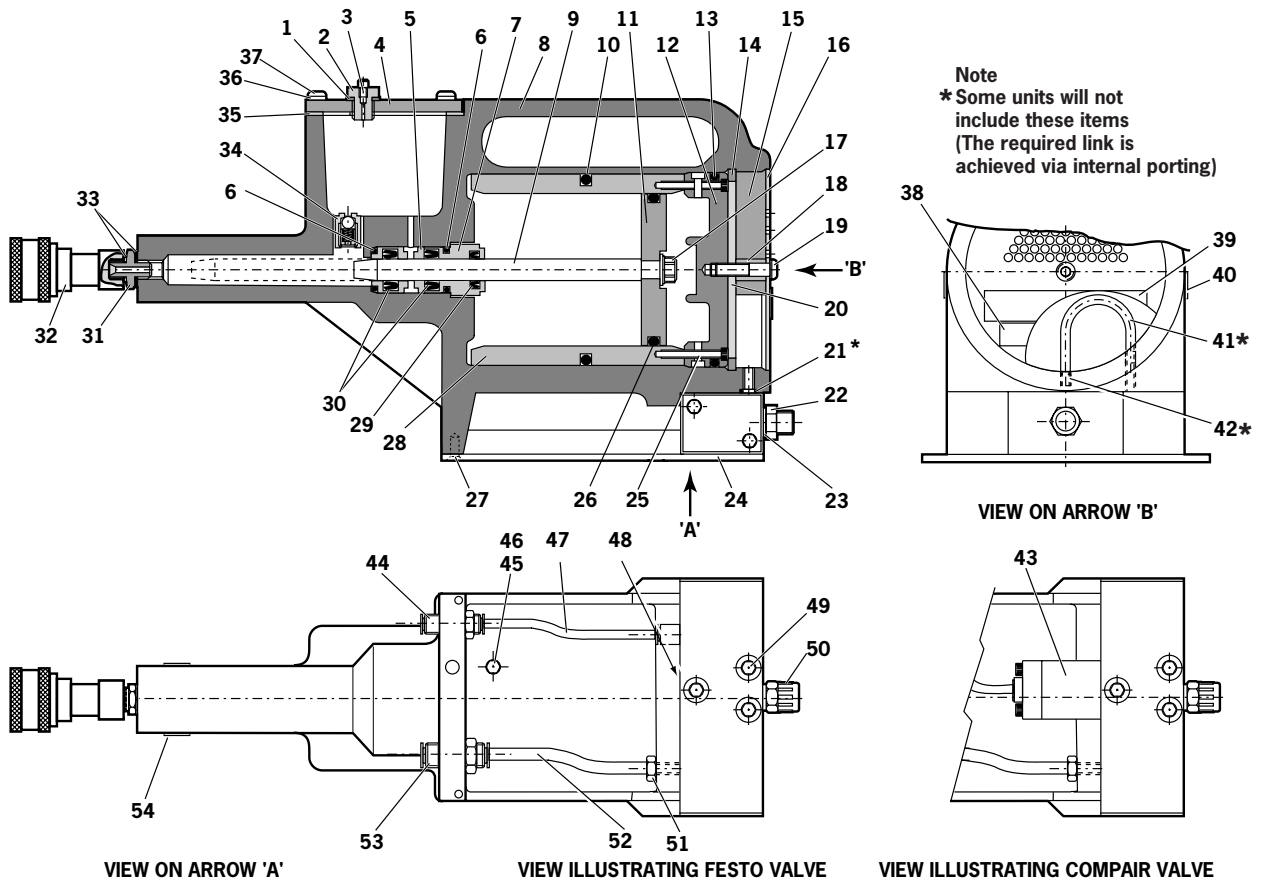

07531-02200 PARTS LIST									
ITEM	PART N°	DESCRIPTION	QTY	SPARES	ITEM	PART N°	DESCRIPTION	QTY	SPARES
1	07003-00037	SEAL	1	1	28	07531-00201	SLEEVE	1	-
2	07240-00211	FILLER SCREW	1	-	29	07003-00337	LIP SEAL	1	1
3	07001-00418	BLEED SCREW	1	1	30	07003-00336	LIP SEAL	2	2
4	07240-00210	COVER PLATE	1	-	31	07005-00406	CONNECTOR	1	-
5	71420-02006	SEAL HOUSING	1	-	32	07005-00759	QUICK RELEASE CONNECTOR	1	-
6	07003-00153	'O' RING	2	-	33	07003-00142	SEAL	2	1
7	71420-02007	SEAL PLUG	1	-	34	07240-00400	VALVE HOUSING ASSEMBLY	1	-
8	71420-02300	BODY ASSEMBLY	1	-	35	07240-00209	GASKET	1	1
9	71420-02008	PISTON ROD	1	-	36	07002-00073	WASHER	4	1
10	07003-00182	'O' RING	1	1	37	07001-00554	SCREW	4	1
11	07531-00202	AIR PISTON	1	-	38	07007-01504	LABEL	1	-
12	07531-00204	END COVER	1	-	39	07240-00217	LABEL	1	-
13	07003-00183	'O' RING	1	1	40	07531-00205	LABEL	2	-
14	07004-00069	RETAINING RING	1	1	41	07005-00596	* 6mm PLASTIC TUBE	-	-
15	07240-00213	FOAM SILENCER	1	1	42	07245-00103	* VACUUM CONNECTOR	2	-
16	07240-00214	SILENCER COVER	1	-	43	07005-00590	COMPAIR VALVE	1	1
17	07002-00017	NUT	1	1	44	07005-01431	BULKHEAD CONNECTOR	1	1
18	07240-00215	SPACER	1	-	45	07005-00668	M5 PLUG	1	-
19	07001-00417	SCREW	1	1	46	07005-00670	M5 SEALING RING	1	-
20	07240-00216	RETAINING PLATE	1	-	47	07005-01084	4mm PLASTIC TUBE (150mm)	-	-
21	* 07003-00042	'O' RING	1	1	48	07005-01524	FESTO VALVE	1	-
22	07005-00041	CONNECTOR	1	-	49	07001-00176	SCREW	3	-
23	07003-00065	WASHER	1	-	50	07007-00292	1/4" BSP REDCAP	1	-
24	07240-00220	PROTECTION PLATE	1	-	51	07005-00647	CONNECTOR	1	-
25	07001-00375	SCREW	2	-	52	07005-01085	6mm PLASTIC TUBE (150mm)	-	-
26	07003-00238	'O' RING	1	1	53	07005-00855	BULKHEAD UNION	1	-
27	07001-00396	SCREW	4	-	54	07007-01503	LABEL	1	-

Pilot Valve 07005-00590 - Maintenance

Dismantling Instructions

Please note that these service instructions refer to the Compair valve where fitted.

Servicing of the valve is limited to the removal/replacement of 'O' rings.

- Remove Screws **24** and remove pilot assembly .
- Remove Piston **11** and discard 'O' Rings **3, 10, 4** and **5**.
- Remove Screws **26** and **21** and remove End Caps **22** and **25**.
- Withdraw Pistons **12** and **18** and remove 'O' Rings **7** and **9** from pistons.
- Withdraw Spool **16** from bore, taking care not to damage surface of spool and remove location Washers **14** and **17**, 'O' Ring **8**, Spacers **15** and 'O' Ring **6** from each end of valve body.
- Remove five interface 'O' Rings **4**.
- Discard ALL 'O' rings removed.
- Clean all parts with paraffin or white spirit. DO NOT USE SOLVENTS. Dry all parts.
- Lightly smear bores of valve Body **23**, pilot valve Body **19**, both End Caps **22** and **25** and all replacement 'O' rings with CENTOPLEX 2 grease.
- Fit new 'O' Rings **10, 4** and **5** to Piston **11** and insert into pilot valve body.
- Fit new 'O' Rings **3, 10** and **6** to pilot valve body, place Top Cap **20** in position and secure pilot valve assembly to main valve Body **23** with Screws **24**. Ensure that the interface seal housing faces upward with the G1/4 at the bottom. Ensure orientation of Piston **11** is correct.
- With main valve Body **23** in the same position, fit green location Washer **17** to the left hand side of the valve assembly.
- Starting from the right hand side of the valve, assemble alternately 'O' Rings **8** and Spacers **15** (6 seals and 5 spacers) and finally complete the stack assembly with white location Washer **14**.
- Lightly smear Spool **16** with CENTOPLEX 2 grease, supplied with the service kit, and slide spool through seal/spacer stack.
- Fit 'O' Rings **9** and **7** to respective Pistons **18** and **12**, fit 'O' Rings **6** to ends of main valve Body **23**.
- Insert pistons into End Caps **25** and **22** and assemble end caps to valve, taking care to locate piston shafts into holes in the ends of Spool **16**.
- Secure end cap assemblies to main valve Body **23** with Screws **26** and **21**.
- Fit interface 'O' Rings **4** into their housings in the main valve body.
- If the pipe connection to the pilot assembly is damaged, replace Plastic Collet **2** and lift out the 'O' Ring **1** from Cartridge **27**.
- Fit new 'O' Ring **1** and insert Plastic Collet **2** into Cartridge **27**.

I M P O R T A N T

Priming is ALWAYS necessary after the tool has been dismantled and prior to operating.

Item numbers in **bold** refer to the illustration and parts list opposite.

Pilot Valve 07005-00590 - Spares Information

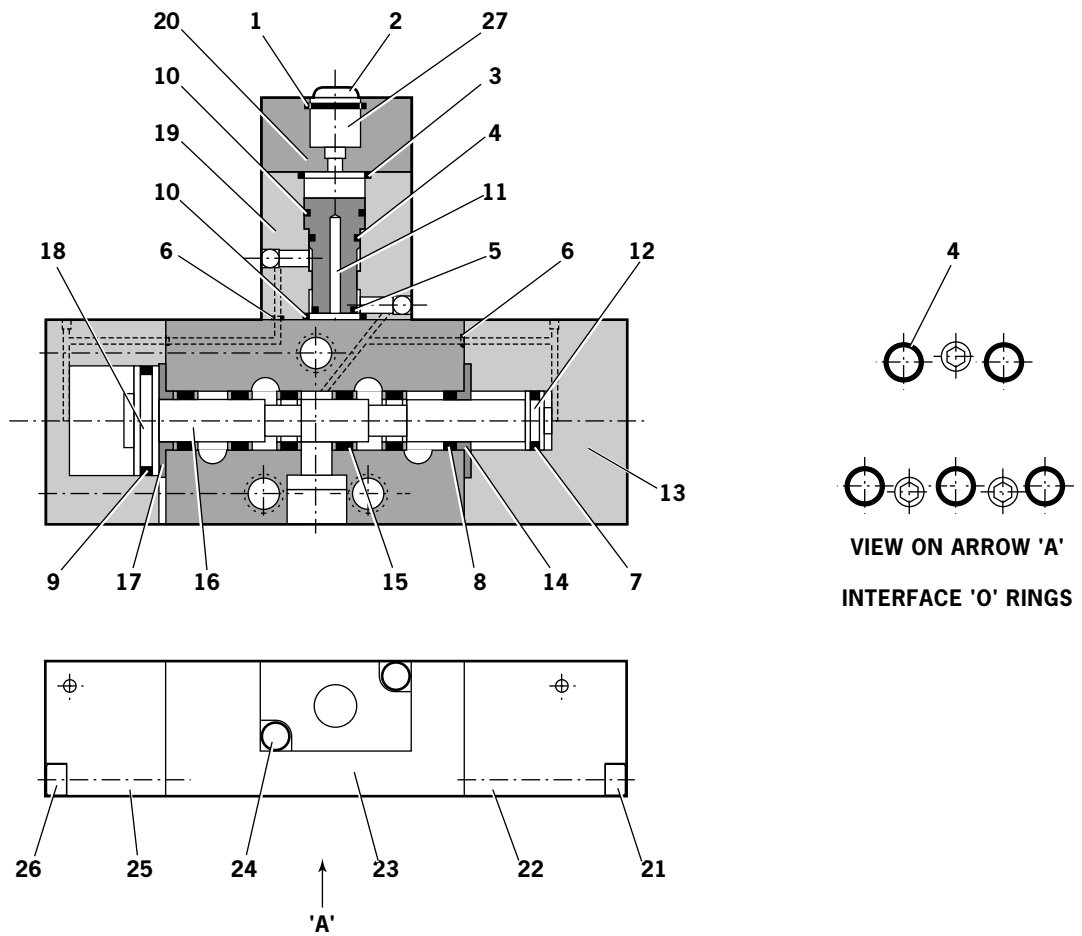

07005-00590 VALVE PARTS LIST

ITEM	PART N°	DESCRIPTION	QTY	SPARES	ITEM	PART N°	DESCRIPTION	QTY	SPARES
1	07005-00599	* 'O' RING	-	-	15	-	† SPACER	5	-
2	07005-00598	* PLASTIC COLLET	-	-	16	-	† SPOOL	1	-
3	07003-00204	* 'O' RING	1	-	17	-	† WASHER	1	-
4	07003-00103	* 'O' RING	6	-	18	-	† PISTON	1	-
5	07003-00042	* 'O' RING	1	-	19	-	† BODY	1	-
6	07003-00121	* 'O' RING	4	-	20	-	† TOP CAP	1	-
7	08005-00127	* 'O' RING	1	-	21	-	† SCREW	2	-
8	07003-00105	* 'O' RING	6	-	22	-	† END CAP	1	-
9	07003-00178	* 'O' RING	1	-	23	-	† BODY	1	-
10	07003-00017	* 'O' RING	2	-	24	-	† SCREW	2	-
11	-	† PISTON	1	-	25	-	† END CAP	1	-
12	-	† PISTON	1	-	26	-	† SCREW	2	-
13	07005-00590	VALVE ASSEMBLY	-	-	27	-	† CARTRIDGE	1	-
14	-	† WASHER	1	-					

* Together these items make up a Service Kit for the valve with the addition of one Centplex 2 tube of grease, the kit is available from Avdel, part number 07005-01538.

† Not available as a spare

Priming

Priming is ALWAYS necessary after the tool has been dismantled and prior to operating. It may also be necessary to restore the full stroke after considerable use, when the stroke may be reduced and fasteners are not fully placed by one operation of the trigger.

Oil Details

The recommended oil for priming is Hyspin VG32 and AWS 32 available in 0.5l (part number 07992-00002) or one gallon containers (part number 07992-00006). Please see safety data below.

Hyspin VG 32 and AWS 32 Oil Safety Data

First Aid

SKIN:

Wash thoroughly with soap and water as soon as possible. Casual contact requires no immediate attention. Short term contact requires no immediate attention.

INGESTION:

Seek medical attention immediately. DO NOT induce vomiting.

EYES:

Irrigate immediately with water for several minutes. Although NOT a primary irritant, minor irritation may occur following contact.

Fire

Suitable extinguishing media: CO₂, dry powder, foam or water fog. DO NOT use water jets.

Environment

WASTE DISPOSAL: Through authorised contractor to a licensed site. May be incinerated. Used product may be sent for reclamation.

SPILLAGE: Prevent entry into drains, sewers and water courses. Soak up with absorbent material.

Handling

Wear eye protection, impervious gloves (e.g. of PVC) and a plastic apron. Use in well ventilated area.

Storage

No special precautions.

Priming Procedure

I M P O R T A N T

DO NOT OPERATE THE TRIGGER WHILE THE BLEED SCREW IS REMOVED

All operations should be carried out on a clean bench, with clean hands in a clean area.

Ensure that the new oil is perfectly clean and free from air bubbles.

Care **MUST** be taken at all times, to ensure that no foreign matter enters the tool, or serious damage may result.

- Remove Screw **2** and Seal **1** from Plastic Cover plate **4** on the intensifier reservoir.
- Pour the priming oil into the reservoir until it is approximately 1/2" (12mm) from the top.
- Replace Screw **2** and Seal **1**.
- Connect the intensifier unit to the air supply. Remove screw from reservoir.
- With the pistol unit fitted to the intensifier unit and held below the level of the intensifier unit, unscrew Bleed Screw **58** from Bleed Plug Assembly **2** on the 07530 Mk II tool or Bleed Screw **66** from Bleed Plug Assembly **30** on the 07532 Mk II tool two turns and allow oil to flow out of the tool.
- When the oil runs freely and free of air bubbles, tighten the bleed screw.
- Top up the reservoir on the intensifier unit with priming oil.
- Cycle the tool until any air bubbles present in the oil are expelled into the oil reservoir.

Item numbers in **bold** refer to the general assemblies and parts lists pages 28-33.

Fault Diagnosis

Symptom	Possible Cause	Remedy	Page Ref
Tool will not place fastener	Low air pressure.	Increase air pressure	
	Lack of lubrication.	Lubricate tool at air inlet point	
	High broach load.	Check fastener grip and application hole size	
	Check for correct size mandrel.		
	Worn or broken tail jaws.	New tail jaws	
	Tail jaws switched off.	Switch on tail jaws	
	Air in hydraulic system.	See 'Priming Procedure'	36
'Mandrel Slip' - jaws will not grip mandrel	Worn or dirty tail jaws.	Clean or renew as necessary	
	' Insufficient air pressure/volume.	Increase air pressure/volume	
	' Tail jaw switch inoperable.	Replace switch	
	' Air leaks to tail jaws.	Renew 'O' rings on piston 8	
	Mandrel broken and not reaching tail jaws.	Replace mandrel	
	Defective non-return valve.	Replace non-return valve	
Jaws will not release mandrel	Dirty tail jaws or jaw housing.	Clean and lubricate	
	Faulty tail jaw switch.	Replace 'O' rings	
Fasteners will not feed through nose jaws	Tail jaws not switched on.	Switch on tail jaws	
	Worn tail jaws.	Renew tail jaws	
	Cursor orientation incorrect.	Refit, ensuring correct orientation	
	Incorrect cursor	Fit correct cursor	
	Incorrect nose jaws.	Fit correct nose jaws	
	Mandrel follower spring not fitted.	Fit correct mandrel follower spring	
	Incorrect gap between fastener head and nose jaws when loaded.	Set gap to 1.5mm - 3mm (1/16" - 1/8") See 'Loading the Tool'	10
	Cursor sticking.	Clean and oil cursor	
	Weak outer spring around cursor.	Renew cursor	
Incorrect mandrel follower spring fitted.	Fit correct mandrel follower spring		
Excessive tail jaw wear	High broach load.	Check application hole size and thickness and fastener grip capability	
Feeding more than one fastener at a time	Mandrel slip.	Check as for 'Mandrel Slip', stage 2	
	Incorrect gap between fastener head and nose jaws when loaded	Set gap to 1.5mm - 3mm (1/16" - 1/8") See 'Loading the Tool'	10

Other symptoms or failures should be reported to your local Avdel authorised distributor or repair centre.

Notes

Declaration of Conformity

We, Avdel UK Limited, Watchmead Industrial Estate, Welwyn Garden City, Herts, AL7 1LY
declare under our sole responsibility that the product:

Model 0753 MkII type 07530 - 07532 models

Hand Tool Serial No.

Intensifier Serial No.

to which this declaration relates is in conformity with the following standards:

EN ISO 12100 - parts 1 & 2

BS EN ISO 8662 - part 6

BS EN ISO 3744

ISO EN 792 part 13 - 2000

BS EN ISO 11202

BS EN 982

BS EN 983

following the provisions of the Machine Directive 98/37/EC



A. Seewraj - Product Engineering Manager - Automation Tools

Date of issue



**This box contains a power tool which is in
conformity with Machines Directive
98/37/EC. The 'Declaration of Conformity' is
contained within.**



An Acument™ Global Technologies Company

AUSTRALIA

Acument Australia Pty Ltd.

891 Wellington Road
Rowville, Victoria 3178
Tel: +61 3 9765 6400
Fax: +61 3 9765 6445
Email: info@acument.com.au

CANADA

Avdel Canada, a Division of Acument Canada Limited.

87 Disco Road
Rexdale
Ontario M9W 1M3
Tel: +1 416 679 0622
Fax: +1 416 679 0678
Email: infoAvdel-Canada@acument.com

CHINA

Acument China Ltd.

RM 1708, 17/F., Nanyang Plaza,
57 Hung To Rd., Kwun Tong
Hong Kong
Tel: +852 2950 0631
Fax: +852 2950 0022
Email: infochina@acument.com

FRANCE

Avdel France S.A.S.

33 bis, rue des Ardennes
BP4
75921 Paris Cedex 19
Tel: +33 (0) 1 4040 8000
Fax: +33 (0) 1 4208 2450
Email: AvdelFrance@acument.com

GERMANY

Avdel Deutschland GmbH

Klusriede 24
30851 Langenhagen
Tel: +49 (0) 511 7288 0
Fax: +49 (0) 511 7288 133
Email: AvdelDeutschland@acument.com

ITALY

Avdel Italia S.r.l.

Viale Lombardia 51/53
20047 Brugherio (MI)
Tel: +39 039 289911
Fax: +39 039 2873079
Email: vendite@acument.com

JAPAN

Acument Japan Kabushiki Kaisha

Center Minami SKY,
3-1 Chigasaki-Chuo, Tsuzuki-ku,
Yokohama-city, Kanagawa Prefecture
Japan 224-0032
Tel: +81 45 947 1200
Fax: +81 45 947 1205
Email: info@acument.co.jp

SINGAPORE

Acument Asia Pacific (Pte) Ltd.

#05-03/06 Techlink
31 Kaki Bukit Road 3
Singapore, 417818
Tel: +65 6840 7431
Fax: +65 6840 7409
Email: Tlim@acument.com

SOUTH KOREA

Acument Korea Ltd.

212-4, Suyang-Ri,
Silchon-Eup, Kwangju-City,
Kyunggi-Do, Korea, 464-874
Tel: +82 31 798 6340
Fax: +82 31 798 6342
Email: info@acumentkorea.com

SPAIN

Avdel Spain S.A.

C/ Puerto de la Morcuera, 14
Poligono Industrial Prado Overa
Ctra. de Toledo, km 7,8
28919 Leganés (Madrid)
Tel: +34 (0) 91 3416767
Fax: +34 (0) 91 3416740
Email: ventas@acument.com

UNITED KINGDOM

Avdel UK Limited

Pacific House
2 Swiftfields
Watchmead Industrial Estate
Welwyn Garden City
Hertfordshire
AL7 1LY
Tel: +44 (0) 1707 292000
Fax: +44 (0) 1707 292199
Email: enquiries@acument.com

USA

Avdel USA LLC

614 NC Highway 200 South
Stanfield,
North Carolina 28163
Tel: +1 704 888-7100
Fax: +1 704 888-0258
Email: infoAvdel-USA@acument.com

© Avdel UK Limited 2007

Manual No.	Issue	Change Note No.
07900-00724	AA	04/088
	B	07/044
	B2	07/103

Avdel®, Avdel® SR, Avlug®, Avsert®, Avtronic®, Briv®, Chobert®, Grovit®, Rivscrew™ are trademarks of Avdel UK Limited.

www.avdel-global.com